

Application Note 01

Usage of the D6T-44L / D6T-8L Thermal sensor



1. Connecting to MCU

Outer View

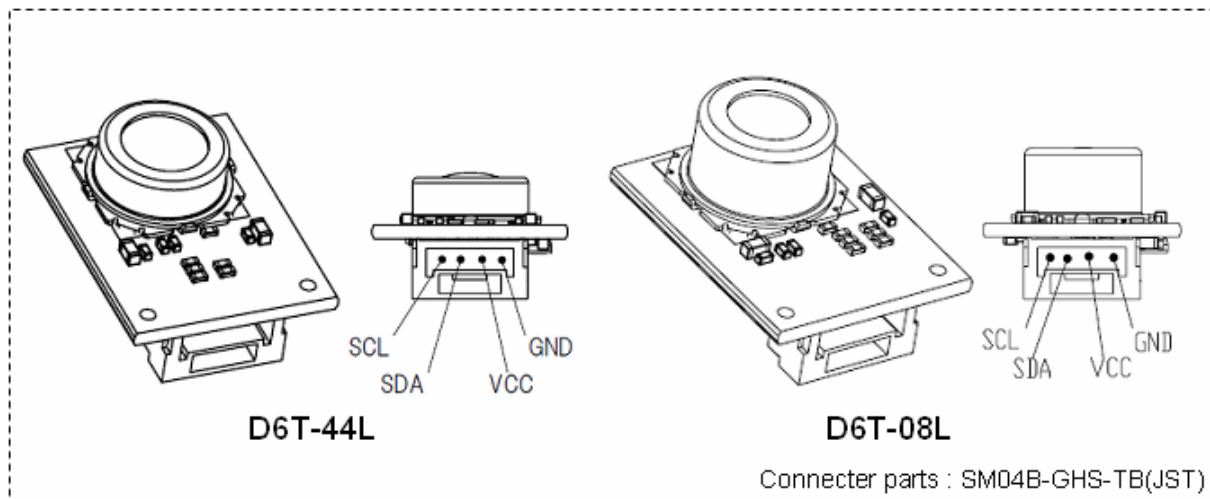

I/O PIN

GND	Ground
VCC	5V +/-10%
SDA	I2C(5V) Data line
SCL	I2C(5V) Clock line

Electrical Connection 1

Case1: 5V MCU (Direct)

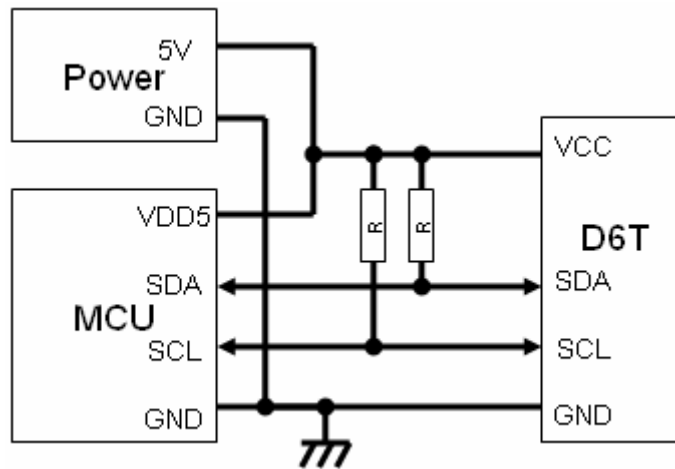

Case2: 3V MCU (5V tolerant I2C port)

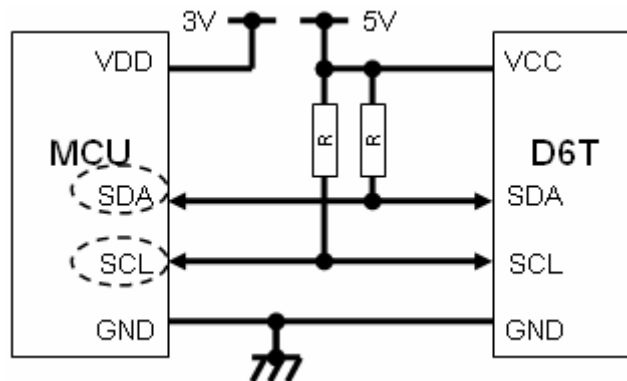

Pull-up Resister :

Impedance value is decided by user.
 (see I2C[100kHz] specification note.)
 (Most case : About 3k to 10k ohm)

Electrical Connection 2

Case3: Using I2C converter

(not 5V tolerant port)

(other LV device is exist)

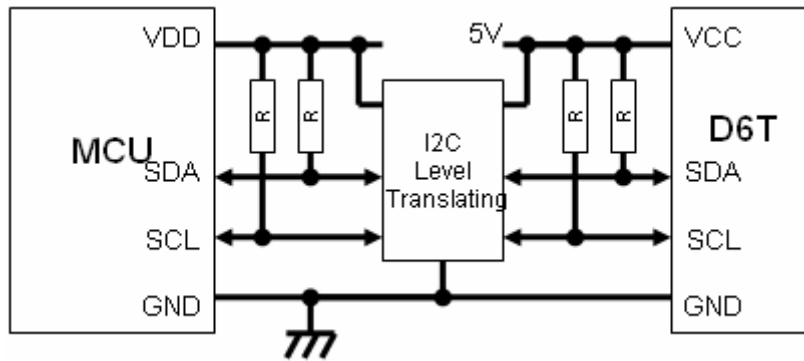

I2C port setting

Address bit width	7bit (0001_010b)
Data bit width	8bit (MSB-first)
Clock Frequency	max 100kHz
Control for Clock-stretching	On (Auto waiting)

 Example Getting the measurement value.

```

// I2C communication functions
extern void I2C_start();
extern void I2C_repeatstart();
extern void I2C_stop();
extern void I2C_send1( char addr8 , char cmd );
extern void I2C_getx( char addr8 , char buff[] , int length );
extern int D6T_checkPEC( char buf , int pPEC );

// Global var.
extern char readbuff[35];
extern int tPTAT;
extern int tP[16];
extern int tPEC;

int D6T_getvalue()
{
    I2C_start();
    I2C_send1( 0x14 , 0x4C ); // 14h = { 0Ah(Addr7) : Write(0b) }
    I2C_repeatstart();
    I2C_getx( 0x15 , readbuff , 35 ); // 15h = { 0Ah(Addr7) : Read(1b) } ,
35 = 2*(1+16)+1
    I2C_stop();
    If(!D6T_checkPEC(readbuff, 34)) {
return -1; // error
    }
    tPTAT = 256*readbuff[1] + readbuff[0];
    tP[0] = 256*readbuff[3] + readbuff[2];
    tP[1] = 256*readbuff[5] + readbuff[4];
    tP[2] = 256*readbuff[7] + readbuff[6];
    tP[3] = 256*readbuff[9] + readbuff[8];
    tP[4] = 256*readbuff[11] + readbuff[10];
    tP[5] = 256*readbuff[13] + readbuff[12];
    tP[6] = 256*readbuff[15] + readbuff[14];
    tP[7] = 256*readbuff[17] + readbuff[16];
    tP[8] = 256*readbuff[19] + readbuff[18];
    tP[9] = 256*readbuff[21] + readbuff[20];
    tP[10] = 256*readbuff[23] + readbuff[22];
    tP[11] = 256*readbuff[25] + readbuff[24];
    tP[12] = 256*readbuff[27] + readbuff[26];
    tP[13] = 256*readbuff[29] + readbuff[28];
    tP[14] = 256*readbuff[31] + readbuff[30];
    tP[15] = 256*readbuff[33] + readbuff[32];
    tPEC = readbuff[34];
    return 1;
}

```

Example PEC check routine

Using PEC value, user can check data validity. (see SMBus specification).

```
unsigned char calc_crc( unsigned char data )
{
    int index;
    unsigned char temp;

    for(index=0; index<8; index++) {
        temp = data;
        data <<= 1;
        if(temp & 0x80) data ^= 0x07;
    }
    return data;
}

int D6T_checkPEC( char buf , int pPEC );
{
    unsigned char crc;
    int i;

    crc = calc_crc( 0x14 );
    crc = calc_crc( 0x4C ^ crc );
    crc = calc_crc( 0x15 ^ crc );
    for(i=0; i<pPEC; i++) {
        crc = calc_crc( readbuff[i] ^ crc );
    }
    return (crc == readbuff[pPEC]);
}
```

Example Detect routine of wait status (Clock-stretching)

Wait request from Slave(Sensor) to Master(MCU).

Master	Slave (Sensor)
a) SCL drive to Lo for Ack.	Checking SCL status.(Lo)
c) SCL output change to Hi-Z.	b) SCL drive to Lo for Wait. Wait...
d) Checking SCL status.(Hi)	e) SCL output change to Hi-Z.(Wait finish)
f) Finish Detected.	
g) Next operation.	

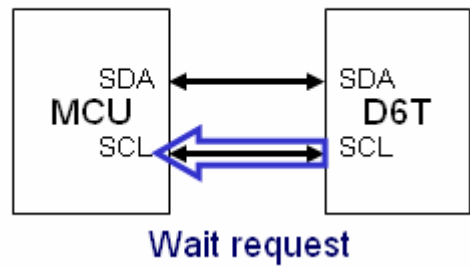
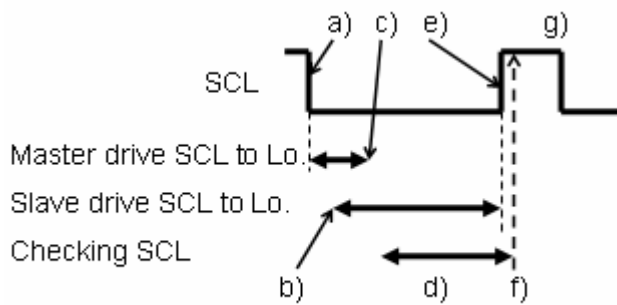

2. Definition of Field of view angle

Maximum sensor output relative to the case of changing the angle of the sensor.
 Angle range of 50% or more sensor output is obtained is defined as the field of view of a Pixel.

Central angle is defined as the difference between angle of the sensor maximum output of each pixel and optical axis.

	Direction X	Direction Y
D6T-8L 1x8		
D6T-44L (4x4)		

3. Distance and range of temperature detection

Detection temperature gets higher in response to the closeness of an object because the sensor detects an average temperature over the targeted area. (Fig.1)

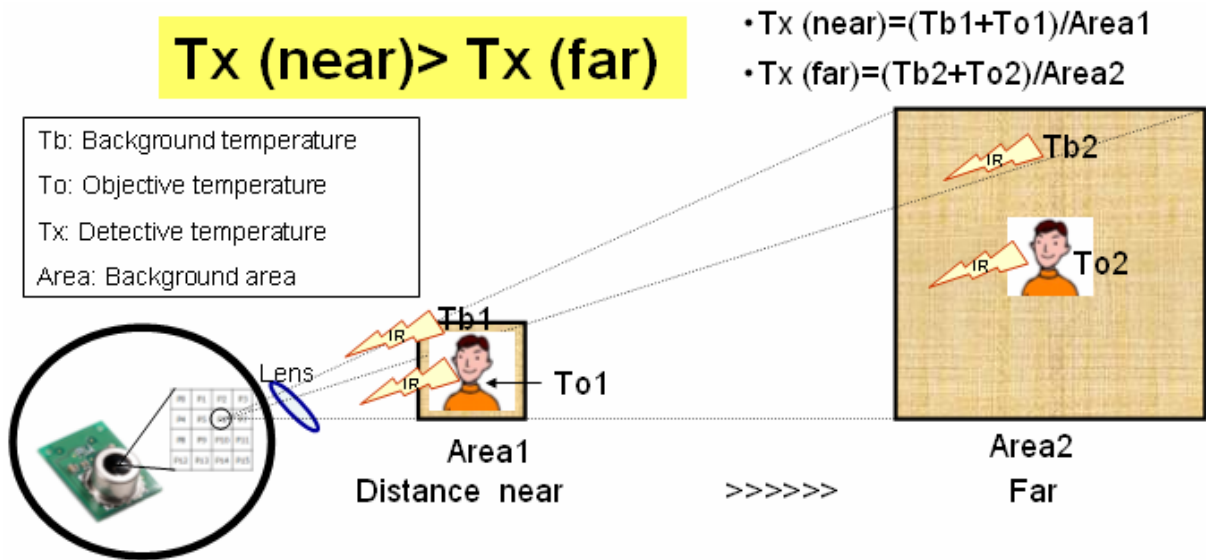

5. Human Detection Thermal Image (1x8 array)

Accurate detection : Floor temperature and detect Human detection.

Even if there are Human : Floor temperature can be measured correctly.

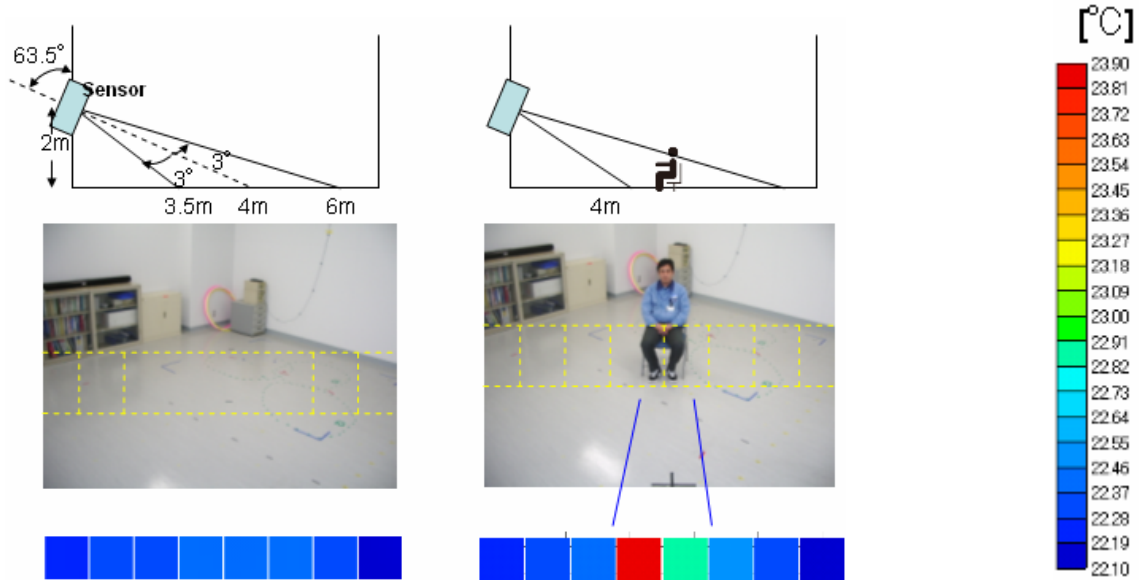

6. Human Detection Thermal Image (4x4 array)

For example, 4x4 array sensor outputs total of 16 temperature value of each element.

Higher temperature is observed where human exist.

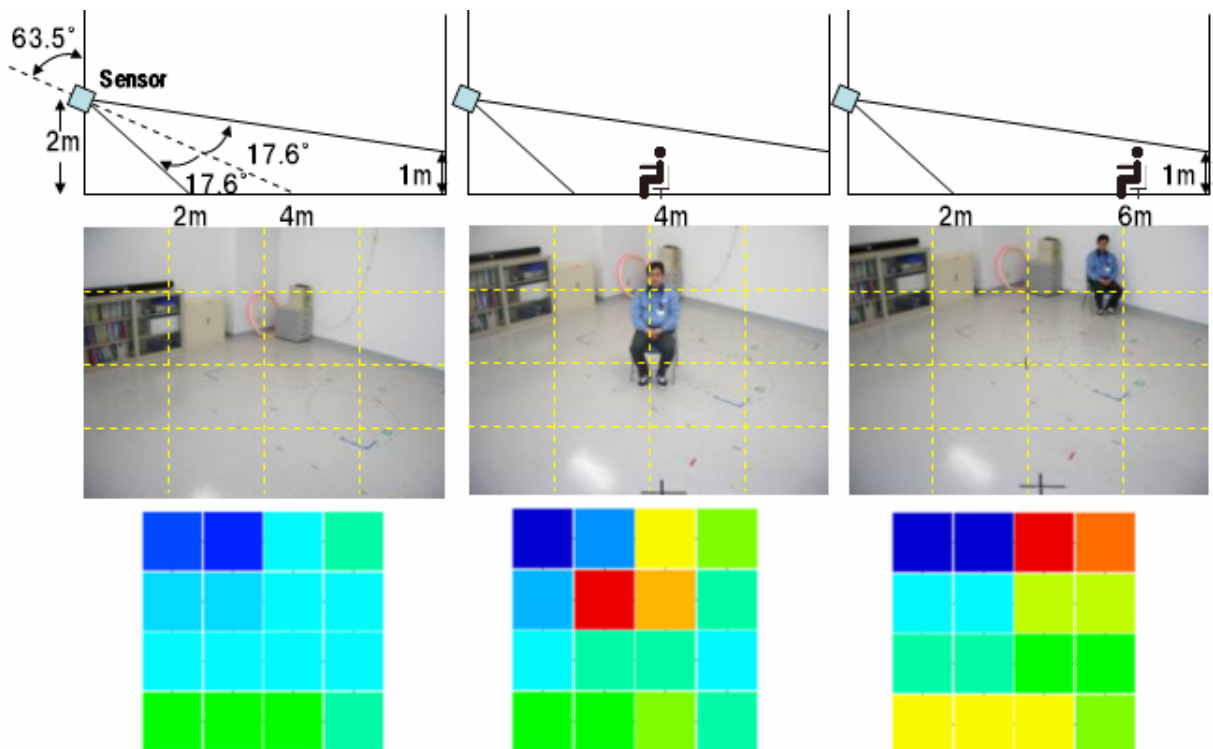

7. Human Detection Thermal Image (4x4 array)

Thermal image may be used for more accurate human detection.

The right figure below shows an example of the thermal image calculated from raw 16 temperature outputs of the 4x4 array Omron MEMS IR sensor.

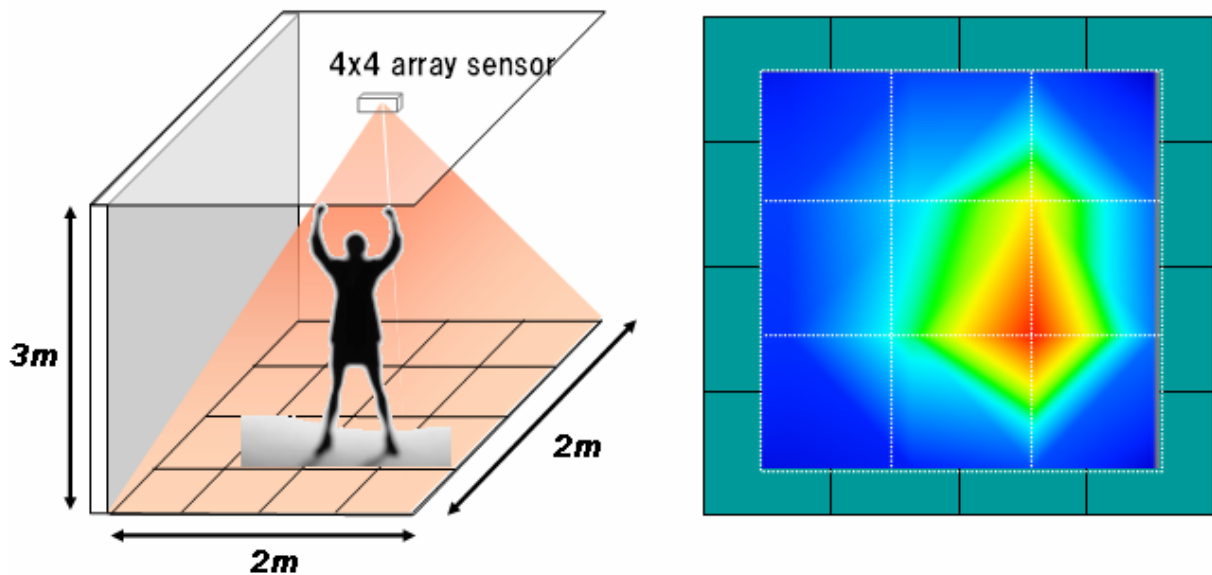

8. Difference in human detection

Compare to conventional pyroelectric sensor, Omron MEMS IR sensor has great advantage in human detection.

Omron IR sensor can detect the presence of human(material with heat)itself, however, pyroelectric sensor can detect the temperature variation only.

That is, if human stays longer at the same spot, pyroelectric sensor loses the signal, but Omron MEMS IR sensor keeps detecting the presence of human.

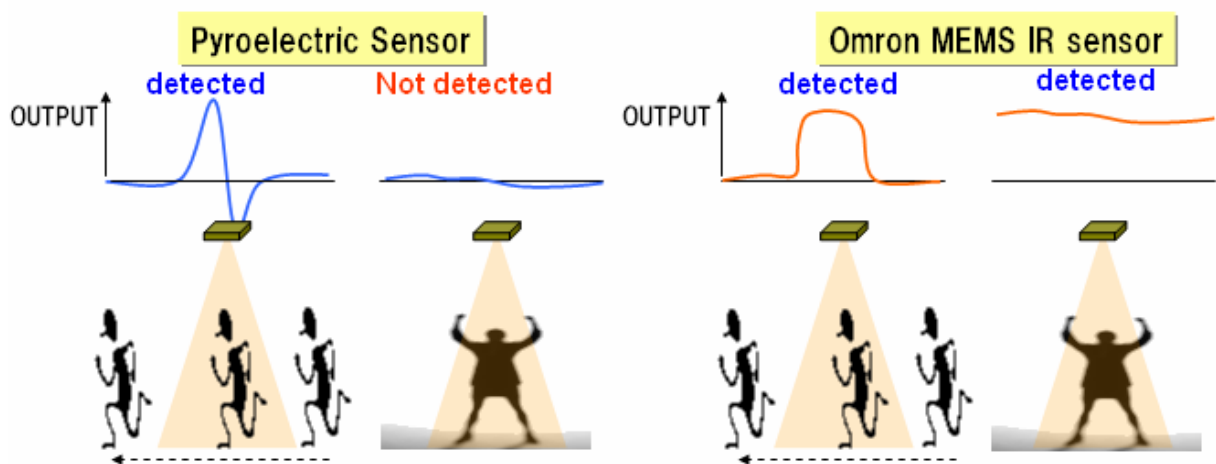

More Information

- **OMRON Electronic Components Web**

<http://www.omron.co.jp/ecb/index.html>

- **Contact Us**

For further inquiry such as delivery, price, sample and/or specification, please contact your local agency or Omron sales representative.

- **Global Sales Office**

<http://www.omron.com/ecb/service/network.html>

- **Mail Contact**

<http://www.omron.com/ecb/contact/index.html>

- **Phone**

Micro Devices Division Tel: **(81) 77-588-9200**

686-1 Ichimiyake, Yasu, Shiga, 520-2326 JAPAN

Revision	DATE	Note
Rev 1.0	July 1,2012	New Released

Notice; Data and specifications are subjected to change without notice.