

# FSB50450US

## Motion SPM<sup>®</sup> 5 FRFET<sup>®</sup> Series

### Features

- 500 V  $R_{DS(on)} = 2.4 \Omega$  (Max) FRFET MOSFET 3-Phase Inverter Including HVICs
- Three Separate Negative DC-Link Terminals for Inverter Current Sensing Applications
- HVIC for Gate Driving and Undervoltage Protection
- Active-High Interface, Can Work With 3.3 V / 5 V Logic
- Optimized for Low Electromagnetic Interference
- Isolation Voltage Rating of 1500 Vrms for 1 min.
- Surface Mounted Device Package
- Moisture Sensitive Level (MSL) 3

### Applications

- 3-Phase Inverter Driver for Small Power AC Motor Drives

### General Description

FSB50450US is an Advanced Motion SPM5 Series Based on Fast-Recovery MOSFET(FRFET) Technology as a Compact Inverter Solution for Small Power Motor Drive Applications Such as Fans and Pumps. It is Composed of Six FRFET MOSFETs and Three Half-Bridge Gate Drive HVICs. FSB50450US Provides Low Electromagnetic Interference(EMI) Characteristics with Optimizing Switching Speed. Moreover, Since It Employs MOSFETs as Power Switches, It has Greater Ruggedness and a Larger Safe Operating Area(SOA) than IGBT-Based Power Modules. The Package is Optimized for Thermal Performance and Compactness for use in Applications Where Space is Limited. FSB50450US is the Right Solution for Inverters Requiring Energy Efficiency, Compactness, and Low Electromagnetic Interference.

### Related Source

- [AN9042 : Motion SPM5 Series Ver.1 User's Guide](#)
- [AN-9082 : Motion SPM5 Series Thermal Performance by Contact Pressure](#)

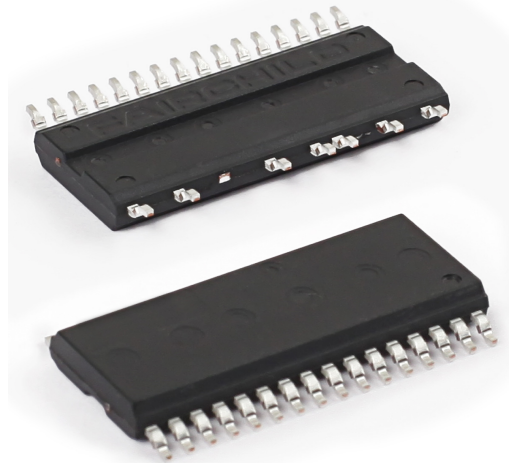

### Package Marking & Ordering Information

| Device Marking | Device     | Package   | Reel Size | Packing Type | Quantity |
|----------------|------------|-----------|-----------|--------------|----------|
| FSB50450US     | FSB50450US | SPM5H-023 | 330 mm    | TAPE & REEL  | 450      |

## Absolute Maximum Ratings

**Inverter Part** (Each MOSFET® Unless Otherwise Specified)

| Symbol       | Parameter   | Conditions  | Rating | Unit      |
|--------------|---|---|--------|-----------|
| $V_{PN}$     | DC Link Input Voltage,<br>Drain-Source Voltage of Each MOSFET |   | 500    | V         |
| * $I_{D 25}$ | Each MOSFET Drain Current, Continuous                         | $T_C = 25^\circ\text{C}$                              | 1.5    | A         |
| * $I_{D 80}$ | Each MOSFET Drain Current, Continuous                         | $T_C = 80^\circ\text{C}$                              | 1.1    | A         |
| * $I_{DP}$   | Each MOSFET Drain Current, Peak                               | $T_C = 25^\circ\text{C}$ , $PW < 100 \mu\text{s}$     | 3.8    | A         |
| * $I_{DRMS}$ | Each MOSFET Drain Current, Rms                                | $T_C = 80^\circ\text{C}$ , $F_{PWM} < 20 \text{ KHz}$ | 0.8    | $A_{rms}$ |
| * $P_D$      | Maximum Power Dissipation                                     | $T_C = 25^\circ\text{C}$ , For Each MOSFET            | 14     | W         |

**Control Part** (Each HVIC Unless Otherwise Specified)

| Symbol   | Parameter              | Conditions                       | Rating                 | Unit |
|----------|------------------------|----------------------------------|------------------------|------|
| $V_{CC}$ | Control Supply Voltage | Applied Between $V_{CC}$ and COM | 20                     | V    |
| $V_{BS}$ | High-side Bias Voltage | Applied Between $V_B$ and $V_S$  | 20                     | V    |
| $V_{IN}$ | Input Signal Voltage   | Applied Between IN and COM       | $-0.3 \sim V_{CC}+0.3$ | V    |

### Thermal Resistance

| Symbol          | Parameter                           | Conditions  | Rating | Unit               |
|-----------------|-------------------------------------|---|--------|--------------------|
| $R_{\theta JC}$ | Junction to Case Thermal Resistance | Each MOSFET under Inverter Operating Condition (Note 1) | 8.9    | $^\circ\text{C/W}$ |

### Total System

| Symbol    | Parameter                      | Conditions   | Rating         | Unit             |
|-----------|--------------------------------|--|----------------|------------------|
| $T_J$     | Operating Junction Temperature |  | $-40 \sim 150$ | $^\circ\text{C}$ |
| $T_{STG}$ | Storage Temperature            |  | $-50 \sim 150$ | $^\circ\text{C}$ |
| $V_{ISO}$ | Isolation Voltage              | 60 Hz, Sinusoidal, 1 minute, Connection Pins to Heatsink | 1500           | $V_{rms}$        |

**Note:**

- For the Measurement Point of Case Temperature  $T_C$ , Please refer to Figure 4.
- Marking "\*" Is Calculation Value or Design Factor.

### Pin descriptions

| Pin Number | Pin Name    | Pin Description  |
|------------|-------------|--|
| 1          | COM         | IC Common Supply Ground                                  |
| 2          | $V_{B(U)}$  | Bias Voltage for U Phase High Side MOSFET® Driving       |
| 3          | $V_{CC(U)}$ | Bias Voltage for U Phase IC and Low Side MOSFET Driving  |
| 4          | $IN_{(UH)}$ | Signal Input for U Phase High-Side                       |
| 5          | $IN_{(UL)}$ | Signal Input for U Phase Low-Side                        |
| 6          | $V_{S(U)}$  | Bias Voltage Ground for U Phase High Side MOSFET Driving |
| 7          | $V_{B(V)}$  | Bias Voltage for V Phase High Side MOSFET Driving        |
| 8          | $V_{CC(V)}$ | Bias Voltage for V Phase IC and Low Side MOSFET Driving  |
| 9          | $IN_{(VH)}$ | Signal Input for V Phase High-Side                       |
| 10         | $IN_{(VL)}$ | Signal Input for V Phase Low-Side                        |
| 11         | $V_{S(V)}$  | Bias Voltage Ground for V Phase High Side MOSFET Driving |
| 12         | $V_{B(W)}$  | Bias Voltage for W Phase High Side MOSFET Driving        |
| 13         | $V_{CC(W)}$ | Bias Voltage for W Phase IC and Low Side MOSFET Driving  |
| 14         | $IN_{(WH)}$ | Signal Input for W Phase High-Side                       |
| 15         | $IN_{(WL)}$ | Signal Input for W Phase Low-Side                        |
| 16         | $V_{S(W)}$  | Bias Voltage Ground for W Phase High Side MOSFET Driving |
| 17         | P           | Positive DC-Link Input                                   |
| 18         | U           | Output for U Phase                                       |
| 19         | $N_U$       | Negative DC-Link Input for U Phase                       |
| 20         | $N_V$       | Negative DC-Link Input for V Phase                       |
| 21         | V           | Output for V Phase                                       |
| 22         | $N_W$       | Negative DC-Link Input for W Phase                       |
| 23         | W           | Output for W Phase                                       |

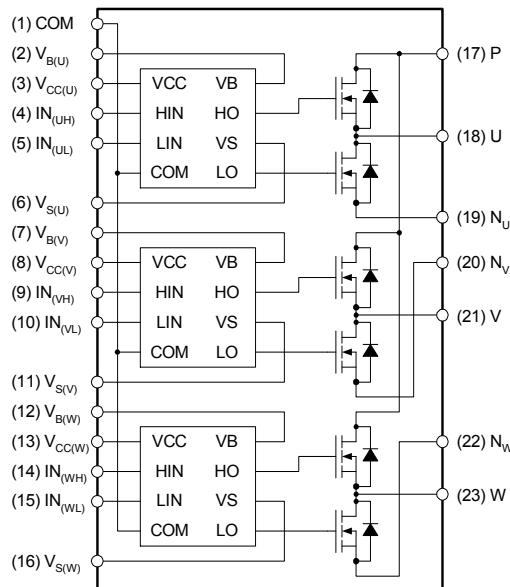

**Note:**

Source Terminal of Each Low-Side MOSFET is Not Connected to Supply Ground or Bias Voltage Ground Inside Motion SPM®.  
 External Connections Should be Made as Indicated in Figure 3

**Figure 1. Pin Configuration and Internal Block Diagram (Bottom View)**

### Electrical Characteristics (T<sub>J</sub> = 25°C, V<sub>CC</sub>=V<sub>BS</sub>= 15 V Unless Otherwise Specified)

#### Inverter Part (Each MOSFET® Unless Otherwise Specified)

| Symbol                              | Parameter                                 | Conditions  | Min         | Typ  | Max | Unit |
|-------------------------------------|---|---|-------------|------|-----|------|
| BV <sub>DSS</sub>                   | Drain-Source Breakdown Voltage            | V <sub>IN</sub> = 0V, I <sub>D</sub> = 1 mA (Note 1)  | 500         | -    | -   | V    |
| ΔBV <sub>DSS</sub> /ΔT <sub>J</sub> | Breakdown Voltage Temperature Coefficient | I <sub>D</sub> = 250μA, Referenced to 25°C  | -           | 0.53 | -   | V    |
| I <sub>DSS</sub>                    | Zero Gate Voltage Drain Current           | V <sub>IN</sub> = 0V, V <sub>DS</sub> = 500 V   | -           | -    | 250 | μA   |
| R <sub>DS(on)</sub>                 | Static Drain-Source On-Resistance         | V <sub>CC</sub> = V <sub>BS</sub> = 15 V, V <sub>IN</sub> = 5 V, I <sub>D</sub> = 0.5 A   | -           | 1.9  | 2.4 | Ω    |
| V <sub>SD</sub>                     | Drain-Source Diode Forward Voltage        | V <sub>CC</sub> = V <sub>BS</sub> = 15V, V <sub>IN</sub> = 0V, I <sub>D</sub> = -0.5 A  | -           | -    | 1.2 | V    |
| t <sub>ON</sub>                     | Switching Times                           | V <sub>PN</sub> = 300 V, V <sub>CC</sub> = V <sub>BS</sub> = 15 V, I <sub>D</sub> = 1.0 A<br>V <sub>IN</sub> = 0 V ↔ 5 V, Inductive Load L= 3 mH<br>High- and Low-Side MOSFET Switching (Note 2)                  | -           | 1250 | -   | ns   |
| t <sub>OFF</sub>                    |   |   | -           | 500  | -   | ns   |
| t <sub>rr</sub>                     |   |   | -           | 200  | -   | ns   |
| E <sub>ON</sub>                     |   |   | -           | 80   | -   | μJ   |
| E <sub>OFF</sub>                    |   |   | -           | 10   | -   | μJ   |
| RBSOA                               | Reverse-Bias Safe Operating Area          | V <sub>PN</sub> = 400 V, V <sub>CC</sub> = V <sub>BS</sub> = 15 V, I <sub>D</sub> = I <sub>DP</sub> , V <sub>DS</sub> =BV <sub>DSS</sub> , T <sub>J</sub> = 150°C<br>High- and Low-Side MOSFET Switching (Note 3) | Full Square |      |     |      |

#### Control Part (Each HVIC Unless Otherwise Specified)

| Symbol            | Parameter                                    | Conditions  | Min | Typ | Max | Unit |
|-------------------|--|---|-----|-----|-----|------|
| I <sub>QCC</sub>  | Quiescent V <sub>CC</sub> Current            | V <sub>CC</sub> =15 V, V <sub>IN</sub> =0V<br>Applied Between V <sub>CC</sub> and COM   | -   | -   | 160 | μA   |
| I <sub>QBS</sub>  | Quiescent V <sub>BS</sub> Current            | V <sub>BS</sub> =15 V, V <sub>IN</sub> =0V<br>Applied Between V <sub>B(U)</sub> -U,<br>V <sub>B(V)</sub> -V, V <sub>B(W)</sub> -W | -   | -   | 100 | μA   |
| UV <sub>CCD</sub> | Low-Side Undervoltage Protection (Figure 6)  | V <sub>CC</sub> Undervoltage Protection Detection Level   | 7.4 | 8.0 | 9.4 | V    |
| UV <sub>CCR</sub> |  | V <sub>CC</sub> Undervoltage Protection Reset Level   | 8.0 | 8.9 | 9.8 | V    |
| UV <sub>BSD</sub> | High-Side Undervoltage Protection (Figure 7) | V <sub>BS</sub> Undervoltage Protection Detection Level   | 7.4 | 8.0 | 9.4 | V    |
| UV <sub>BSR</sub> |  | V <sub>BS</sub> Undervoltage Protection Reset Level   | 8.0 | 8.9 | 9.8 | V    |
| V <sub>IH</sub>   | ON Threshold Voltage                         | Logic High Level  | 3.0 | -   | -   | V    |
| V <sub>IL</sub>   | OFF Threshold Voltage                        | Logic Low Level   |     |     |     |      |
| I <sub>IH</sub>   | Input Bias Current                           | V <sub>IN</sub> = 5V  | -   | 10  | 20  | μA   |
| I <sub>IL</sub>   |  | V <sub>IN</sub> = 0V  | -   | -   | 2   | μA   |

**Note:**

- BV<sub>DSS</sub> is the Absolute Maximum Voltage Rating Between Drain and Source Terminal of Each MOSFET Inside Motion SPM®. V<sub>PN</sub> Should be Sufficiently Less Than This Value Considering the Effect of the Stray Inductance so that V<sub>DS</sub> Should Not Exceed BV<sub>DSS</sub> in Any Case.
- t<sub>ON</sub> and t<sub>OFF</sub> Include the Propagation Delay Time of the Internal Drive IC. Listed Values are Measured at the Laboratory Test Condition, and They Can be Different According to the Field Applications Due to the Effect of Different Printed Circuit Boards and Wirings. Please see Figure 4 for the Switching Time Definition with the Switching Test Circuit of Figure 5.
- The peak current and voltage of each MOSFET during the switching operation should be included in the safe operating area (SOA). Please see Figure 5 for the RBSOA test circuit that is same as the switching test circuit.

## Recommended Operating Condition

| Symbol        | Parameter                              | Conditions  | Value |      |          | Unit          |
|---------------|--|---|-------|------|----------|---------------|
|               |  |   | Min.  | Typ. | Max.     |               |
| $V_{PN}$      | Supply Voltage                         | Applied Between P and N   | -     | 300  | 400      | V             |
| $V_{CC}$      | Control Supply Voltage                 | Applied Between $V_{CC}$ and COM                                      | 13.5  | 15   | 16.5     | V             |
| $V_{BS}$      | High-Side Bias Voltage                 | Applied Between $V_B$ and $V_S$                                       | 13.5  | 15   | 16.5     | V             |
| $V_{IN(ON)}$  | Input ON Threshold Voltage             | Applied Between IN and COM  | 3.0   | -    | $V_{CC}$ | V             |
| $V_{IN(OFF)}$ | Input OFF Threshold Voltage            |   | 0     | -    | 0.6      | V             |
| $t_{dead}$    | Blanking Time for Preventing Arm-Short | $V_{CC}=V_{BS}= 13.5 \sim 16.5 \text{ V}, T_J \leq 150^\circ\text{C}$ | 1.0   | -    | -        | $\mu\text{s}$ |
| $f_{PWM}$     | PWM Switching Frequency                | $T_J \leq 150^\circ\text{C}$  | -     | 15   | -        | kHz           |

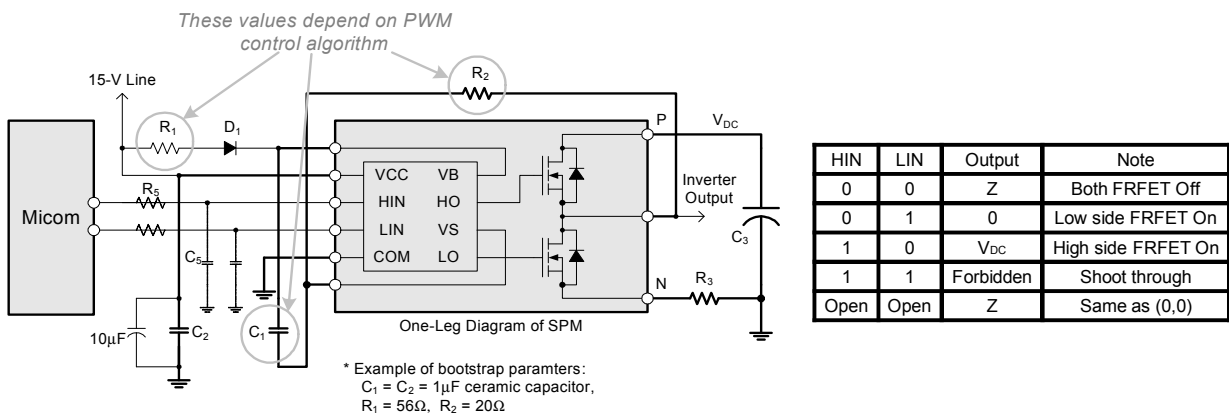

**Note:**

1. It is Recommended the Bootstrap Diode  $D_1$  to Have Soft and Fast Recovery Characteristics with 600-V Rating.
2. Parameters for Bootstrap Circuit Elements are Dependent on PWM Algorithm. For 15 kHz of Switching Frequency, Typical Example of Parameters is Shown Above.
3. RC coupling ( $R_5$  and  $C_5$ ) at Each Input of Motion SPM® and Microm (Indicated as Dotted Lines) May be Used to Prevent Improper Signal Due to Surge Noise.
4. Bold lines should be short and thick in PCB pattern to have small stray inductance of circuit, which results in the reduction of surge voltage. Bypass capacitors such as  $C_1, C_2$  and  $C_3$  Should Have Good High-Frequency characteristics to Absorb High-Frequency Ripple Current.

**Figure 2. Recommended MCU Interface and Bootstrap Circuit with Parameters**

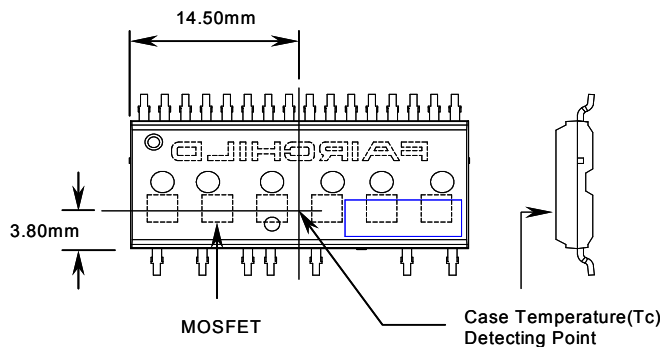

**Note:**

Attach the thermocouple on top of the heatsink-side of Motion SPM (between Motion SPM and heatsink if applied) to get the correct temperature measurement.

**Figure 3. Case Temperature Measurement**

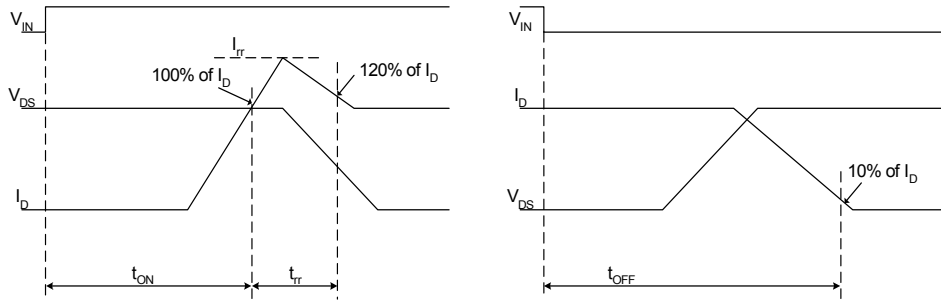

(a) Turn-on (b) Turn-off  
**Figure 4. Switching Time Definitions**

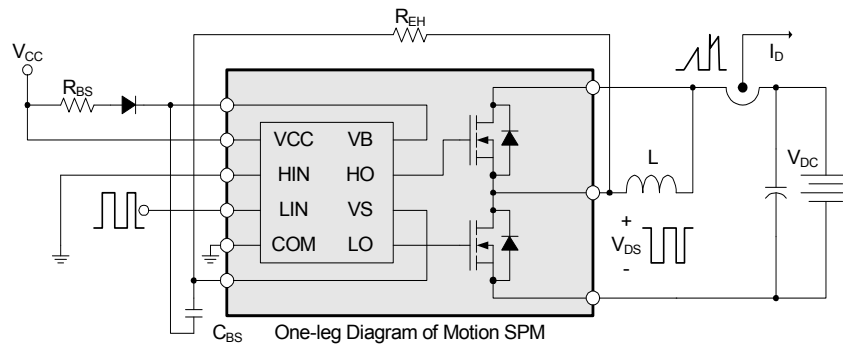

**Figure 5. Switching and RBSOA (Single-pulse) Test Circuit (Low-side)**

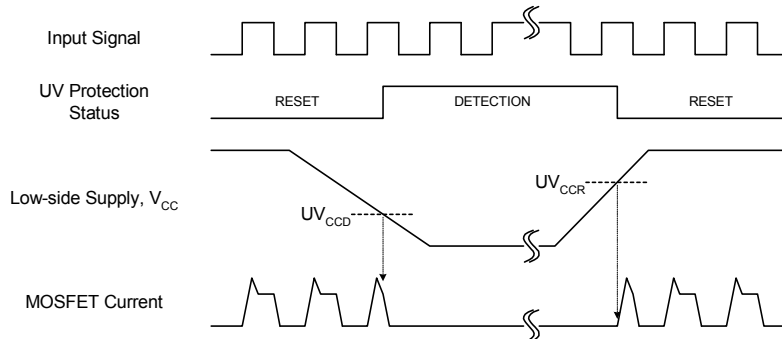

**Figure 6. Undervoltage Protection (Low-side)**

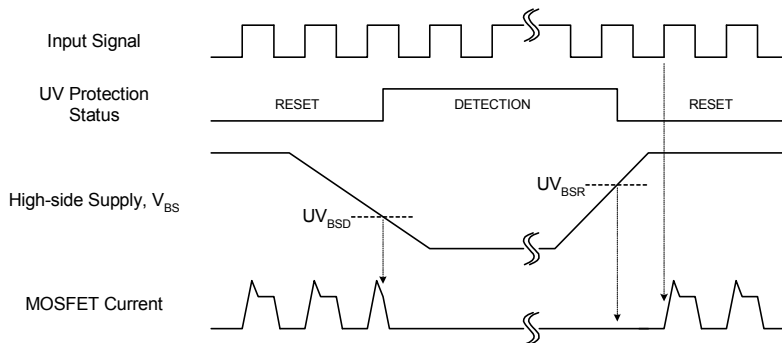

**Figure 7. Undervoltage Protection (High-side)**

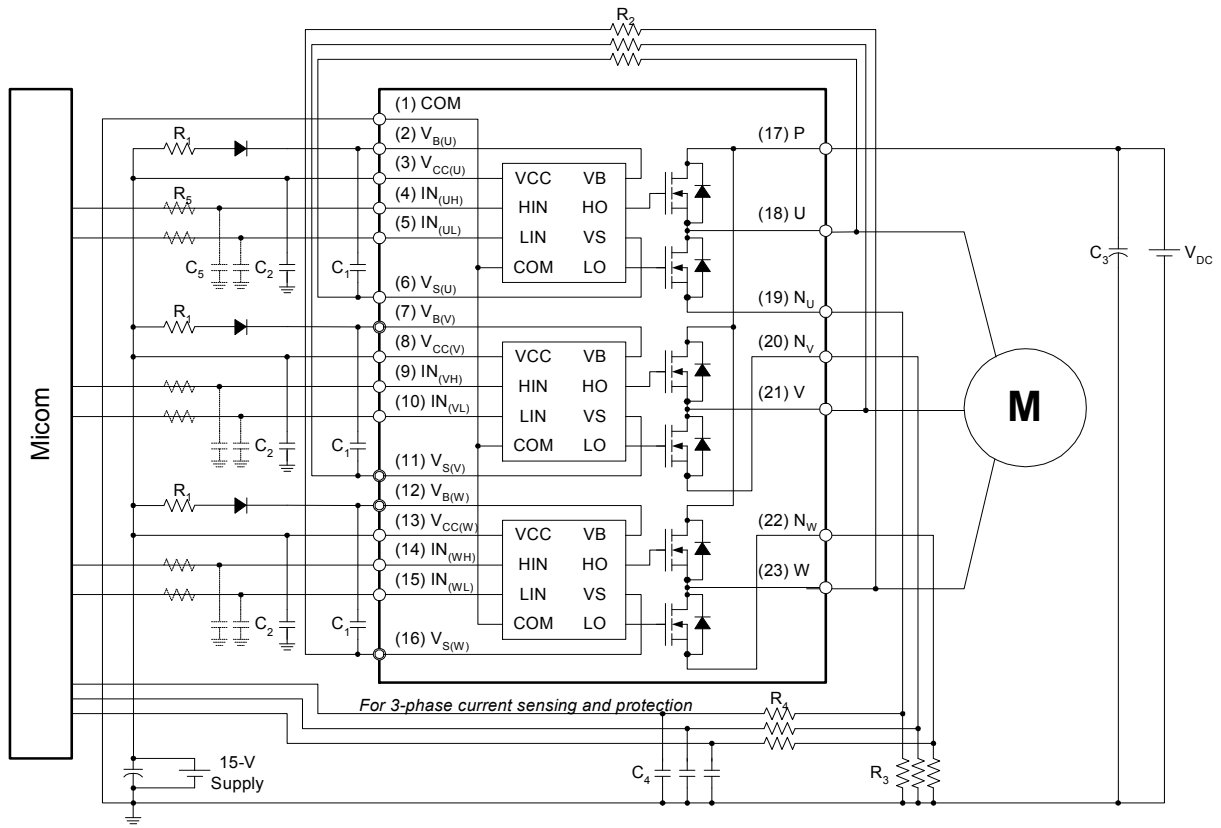

**Note:**

1. About Pin Position, Refer to Figure 1.
2. RC Coupling ( $R_5$  and  $C_5$ ,  $R_4$  and  $C_4$ ) at Each Input of Motion SPM® and Microm are Useful to Prevent Improper Input Signal Caused by Surge Noise.
3. The voltage Drop Across  $R_3$  Affects the Low Side Switching Performance and the Bootstrap Characteristics Since it is Placed Between COM and the Source Terminal of the Low Side MOSFET. For this Reason, the Voltage Drop Across  $R_3$  Should Be Less Than 1 V in the Steady-State.
4. Ground Wires and Output Terminals, Should Be Thick and Short in Order to Avoid Surge Voltage and Malfunction of HVIC.
5. All the Filter Capacitors Should Be Connected Close to Motion SPM, and They Should Have Good Characteristics for Rejecting High-Frequency Ripple Current.

**Figure 8. Example of Application Circuit**

### Detailed Package Outline Drawings

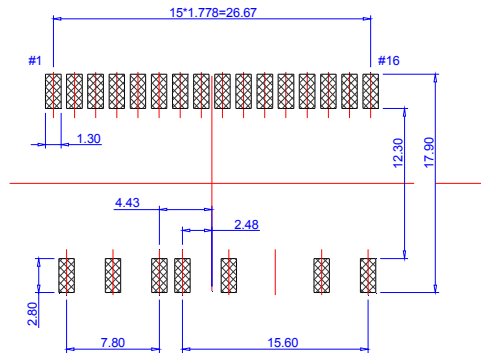
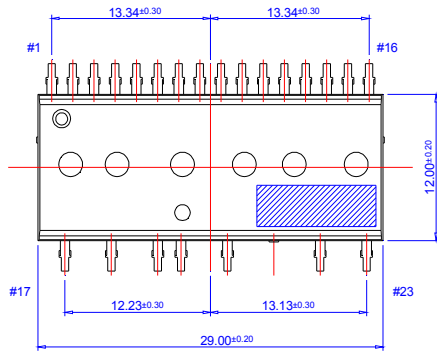
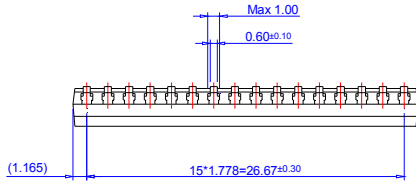

LAND PATTERN RECOMMENDATIONS

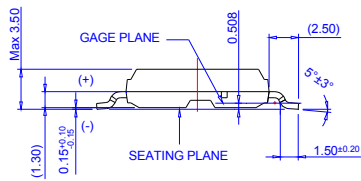
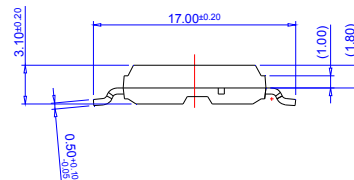
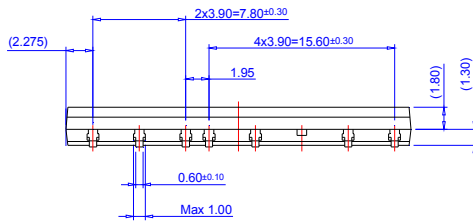







**TRADEMARKS**

The following includes registered and unregistered trademarks and service marks, owned by Fairchild Semiconductor and/or its global subsidiaries, and is not intended to be an exhaustive list of all such trademarks.

Build it Now™  
 CorePLUS™  
 CorePOWER™  
 CROSSVOLT™  
 CTL™  
 Current Transfer Logic™  
 EcoSPARK®  
 EfficientMax™  
 EZSWITCH™ \*  
  
  
 Fairchild®  
 Fairchild Semiconductor®  
 FACT Quiet Series™  
 FACT®  
 FAST®  
 FastvCore™  
 FlashWriter® \*  
 FPS™  
 F-PFS™

FRFET®  
 Global Power Resource™  
 Green FPS™  
 Green FPS™ e-Series™  
 GTO™  
 IntelliMAX™  
 ISOPLANAR™  
 MegaBuck™  
 MICROCOPLER™  
 MicroFET™  
 MicroPak™  
 MillerDrive™  
 MotionMax™  
 Motion-SPM™  
 OPTOLOGIC®  
 OPTOPLANAR®  
  
 PDP SPM™  
 Power-SPM™  
 PowerTrench®  
 PowerXS™

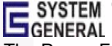
Programmable Active Droop™  
 QFET®  
 QS™  
 Quiet Series™  
 RapidConfigure™  
  
 Saving our world, 1mW /W /kW at a time™  
 SmartMax™  
 SMART START™  
 SPM®  
 STEALTH™  
 SuperFET™  
 SuperSOT™\_3  
 SuperSOT™\_6  
 SuperSOT™\_8  
 SupreMOS™  
 SyncFET™  
  
 The Power Franchise®

the power franchise  
 TinyBoost™  
 TinyBuck™  
 TinyLogic®  
 TINYOPTO™  
 TinyPower™  
 TinyPWM™  
 TinyWire™  
 TriFault Detect™  
 μSerDes™  
  
 UHC®  
 Ultra FRFET™  
 UniFET™  
 VCX™  
 VisualMax™  
 XS™

\* EZSWITCH™ and FlashWriter® are trademarks of System General Corporation, used under license by Fairchild Semiconductor.

**DISCLAIMER**

FAIRCHILD SEMICONDUCTOR RESERVES THE RIGHT TO MAKE CHANGES WITHOUT FURTHER NOTICE TO ANY PRODUCTS HEREIN TO IMPROVE RELIABILITY, FUNCTION, OR DESIGN. FAIRCHILD DOES NOT ASSUME ANY LIABILITY ARISING OUT OF THE APPLICATION OR USE OF ANY PRODUCT OR CIRCUIT DESCRIBED HEREIN; NEITHER DOES IT CONVEY ANY LICENSE UNDER ITS PATENT RIGHTS, NOR THE RIGHTS OF OTHERS. THESE SPECIFICATIONS DO NOT EXPAND THE TERMS OF FAIRCHILD'S WORLDWIDE TERMS AND CONDITIONS, SPECIFICALLY THE WARRANTY THEREIN, WHICH COVERS THESE PRODUCTS.

**LIFE SUPPORT POLICY**

FAIRCHILD'S PRODUCTS ARE NOT AUTHORIZED FOR USE AS CRITICAL COMPONENTS IN LIFE SUPPORT DEVICES OR SYSTEMS WITHOUT THE EXPRESS WRITTEN APPROVAL OF FAIRCHILD SEMICONDUCTOR CORPORATION.

As used herein:

- Life support devices or systems are devices or systems which, (a) are intended for surgical implant into the body or (b) support or sustain life, and (c) whose failure to perform when properly used in accordance with instructions for use provided in the labeling, can be reasonably expected to result in a significant injury of the user.
- A critical component in any component of a life support, device, or system whose failure to perform can be reasonably expected to cause the failure of the life support device or system, or to affect its safety or effectiveness.

**ANTI-COUNTERFEITING POLICY**

Fairchild Semiconductor Corporation's Anti-Counterfeiting Policy. Fairchild's Anti-Counterfeiting Policy is also stated on our external website, [www.fairchildsemi.com](http://www.fairchildsemi.com), under Sales Support.

Counterfeiting of semiconductor parts is a growing problem in the industry. All manufactures of semiconductor products are experiencing counterfeiting of their parts. Customers who inadvertently purchase counterfeit parts experience many problems such as loss of brand reputation, substandard performance, failed application, and increased cost of production and manufacturing delays. Fairchild is taking strong measures to protect ourselves and our customers from the proliferation of counterfeit parts. Fairchild strongly encourages customers to purchase Fairchild parts either directly from Fairchild or from Authorized Fairchild Distributors who are listed by country on our web page cited above. Products customers buy either from fairchild directly or from Authorized Fairchild Distributors are genuine parts, have full traceability, meet Fairchild's quality standards for handling and storage and provide access to Fairchild's full range of up-to-date technical and product information. Fairchild and our Authorized Distributors will stand behind all warranties and will appropriately address and warranty issues that may arise. Fairchild will not provide any warranty coverage or other assistance for parts bought from Unauthorized Sources. Fairchild is committed to combat this global problem and encourage our customers to do their part in stopping this practice by buying direct or from authorized distributors.

**PRODUCT STATUS DEFINITIONS**

**Definition of Terms**

| Datasheet Identification | Product Status        | Definition  |
|--------------------------|-----------------------|---|
| Advance Information      | Formative / In Design | Datasheet contains the design specifications for product development. Specifications may change in any manner without notice.   |
| Preliminary              | First Production      | Datasheet contains preliminary data; supplementary data will be published at a later date. Fairchild Semiconductor reserves the right to make changes at any time without notice to improve design. |
| No Identification Needed | Full Production       | Datasheet contains final specifications. Fairchild Semiconductor reserves the right to make changes at any time without notice to improve the design.   |
| Obsolete                 | Not In Production     | Datasheet contains specifications on a product that is discontinued by Fairchild Semiconductor. The datasheet is for reference information only.  |

Rev. I38