

FPAB20BH60B PFC SPM® 3 Series for 1-Phase Boost PFC

Features

- Low Thermal Resistance Thanks to Al₂O₃-DBC Substrate
- 600 V - 20 A 1-Phase Boost PFC Including A Drive IC for Gate Driving and Protection
- Built-In NTC Thermistor for Monitoring Over-Temperature
- Typical Switching Frequency of 20 kHz
- Isolation Rating of 2500 Vrms/min.

Applications

- 1-Phase Boost PFC Converter for Air Conditioner

General Description

FPAB20BH60B Is An Advanced PFC SPM 3 Series for 1-Phase Boost PFC (Power Factor Correction) that Fairchild Has Newly Developed for Mid-Power Applications such as Air Conditioners. It Combines Optimized Circuit Protections and A Drive IC Matched to High Frequency Switching IGBT. The System Reliability Is Further Enhanced by The Integrated Under-Voltage Lock-Out and Over-Current Protection Function.

Related Source

- [Will Be Released](#)

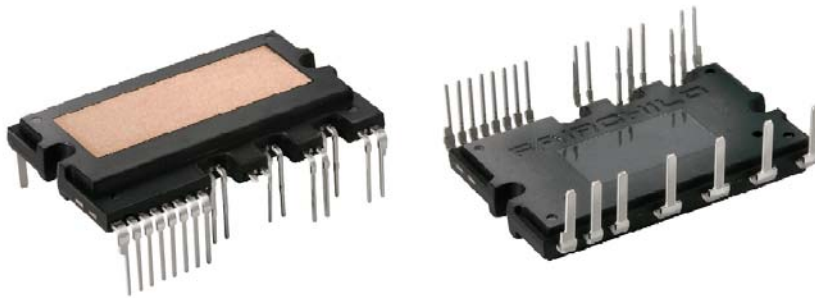

Fig. 1. Package Overview

Package Marking & Ordering Information

Device Marking	Device	Package	Packing Type	Reel Size	Tape Width	Quantity
FPAB20BH60B	FPAB20BH60B	SPMIC-027	RAIL	-	-	10

Integrated Power Functions

- PFC converter for 1-phase AC/DC power conversion (Please refer to Fig. 3)

Integrated Drive, Protection and System Control Functions

- For IGBTs : Gate drive circuit, Over Current(OC) protection, Control supply circuit Under-Voltage(UV) protection
- Fault signal : Corresponding to OC and UV fault
- Built-in thermistor: Over-temperature monitoring
- Input interface : Active-high interface, can work with 3.3 / 5 V Logic, Schmitt trigger input

Pin Configuration

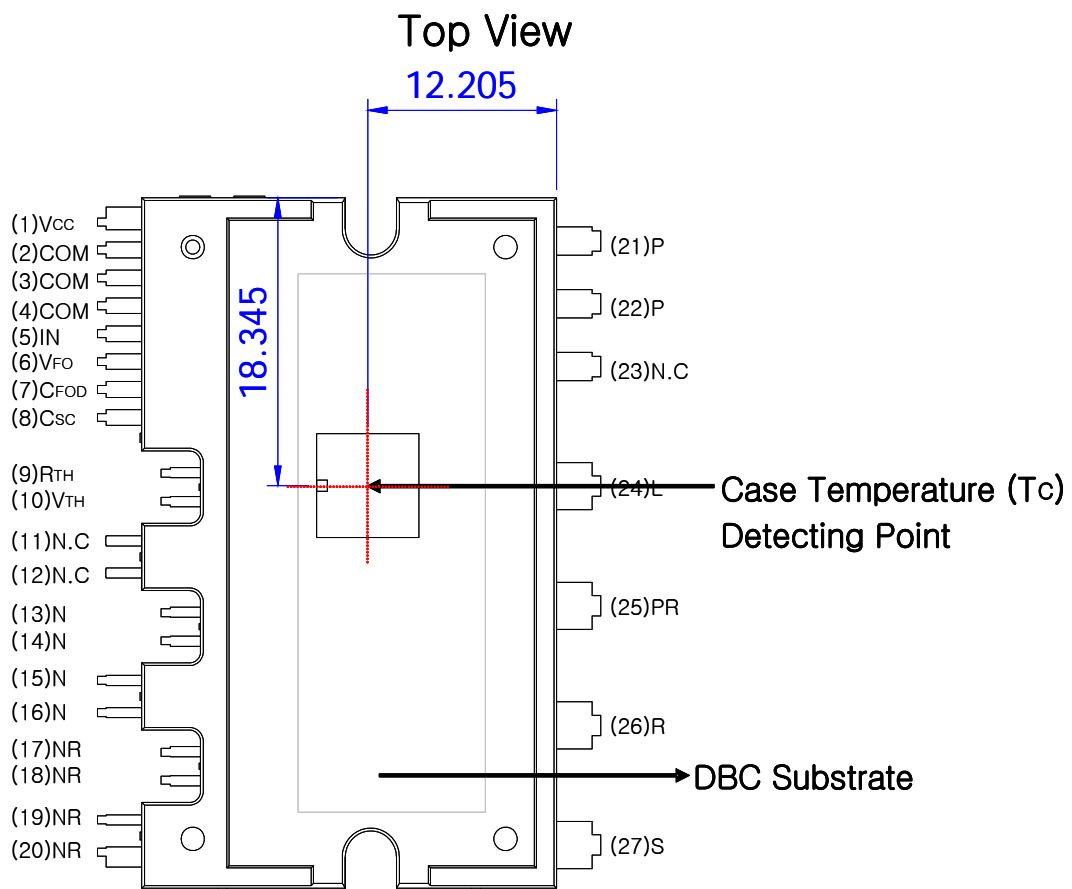

Fig. 2.

Note : For the measurement point of case temperature(T_c), please refer to Fig. 2.

Pin Descriptions

Pin Number	Pin Name	Pin Description
1	V _{CC}	Common Bias Voltage for IC and IGBT Driving
2,3,4	COM	Common Supply Ground
5	IN	Signal Input for IGBT
6	V _{FO}	Fault Output
7	C _{FOD}	Capacitor for Fault Output Duration Time Selection
8	C _{SC}	Capacitor (Low-pass Filter) for Over Current Detection
9	R _(TH)	NTC Thermistor terminal
10	V _(TH)	NTC Thermistor terminal
11,12	N.C	No Connection*
13~16	N	IGBT emitter
17~20	N _R	Negative DC-Link of Rectifier
21,22	P	Positive Rail of DC-Link
23	N.C	No Connection
24	L	Reactor connection pin
25	P _R	Positive DC-Link of Rectifier
26	R	AC input for R-phase
27	S	AC input for S-phase

* 11th and 12th pins are cut. Please refer to package outline drawings for more detail.

Internal Equivalent Circuit and Input/Output Pins

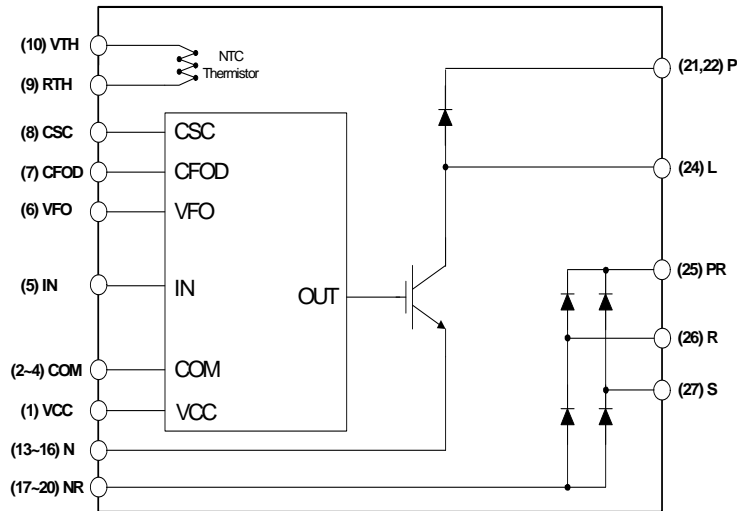

Fig. 3.

Absolute Maximum Ratings ($T_J = 25^\circ\text{C}$, Unless Otherwise Specified)

Converter Part

Item	Symbol	Condition	Rating	Unit
Input Supply Voltage	V_i	Applied between R-S	264	V_{RMS}
Input Supply Voltage (Surge)	$V_{i(\text{Surge})}$	Applied between R-S	500	V
Output Voltage	V_{PN}	Applied between P- N	450	V
Output Voltage (Surge)	$V_{\text{PN}(\text{Surge})}$	Applied between P- N	500	V
Collector-emitter Voltage	V_{CES}		600	V
Each IGBT Collector Current	I_C	$T_C = 25^\circ\text{C}$, $T_J < 150^\circ\text{C}$	20	A
Each IGBT Collector Current (peak)	I_{CP}	$T_C = 25^\circ\text{C}$, $T_J < 150^\circ\text{C}$ Under 1ms pulse width	40	A
Collector Dissipation	P_C	$T_C = 25^\circ\text{C}$ per One IGBT	89	W
Repetitive Peak Reverse Voltage	V_{RRM}		600	V
Peak Forward Surge Current	I_{FSM}	Single half sine-wave	250	A
Operating Junction Temperature	T_J		-40 ~ 150	$^\circ\text{C}$

Control Part

Item	Symbol	Condition	Rating	Unit
Control Supply Voltage	V_{CC}	Applied between V_{CC} - COM	20	V
Input Signal Voltage	V_{IN}	Applied between IN - COM	-0.3- V_{CC} +0.3	V
Fault Output Supply Voltage	V_{FO}	Applied between V_{FO} - COM	-0.3- V_{CC} +0.3	V
Fault Output Current	I_{FO}	Sink Current at V_{FO} Pin	5	mA
Current Sensing Input Voltage	V_{SC}	Applied between C_{SC} - COM	-0.3- V_{CC} +0.3	V

Total System

Item	Symbol	Condition	Rating	Unit
Storage Temperature	T_{STG}		-40 ~ 125	$^\circ\text{C}$
Isolation Voltage	V_{ISO}	60 Hz, Sinusoidal, AC 1 minute, Connection Pins to DBC	2500	V_{rms}

Thermal Resistance

Item	Symbol	Condition	Min.	Typ.	Max.	Unit
Junction to Case Thermal Resistance	$R_{\theta(j-c)Q}$	IGBT	-	-	1.4	$^\circ\text{C/W}$
	$R_{\theta(j-c)F}$	FRD	-	-	1.4	$^\circ\text{C/W}$
	$R_{\theta(j-c)R}$	Rectifier	-	-	2.1	$^\circ\text{C/W}$

Electrical Characteristics (T_J = 25°C, Unless Otherwise Specified)

Converter Part

Item	Symbol	Condition	Min.	Typ.	Max.	Unit
IGBT saturation voltage	V _{CE(sat)}	V _{CC} = 15 V, V _{IN} = 5 V; I _C = 20 A	-	2.3	3.0	V
FRD forward voltage	V _{FF}	I _F = 20 A	-	1.8	2.5	V
Rectifier forward voltage	V _{FR}	I _F = 20 A	-	1.2	1.5	V
Switching Times	t _{ON}	V _{PN} = 400 V, V _{CC} = 15 V, I _C = 20 A V _{IN} = 0 V ↔ 5 V, Inductive Load (Note 1)	-	450	-	ns
	t _{C(ON)}		-	200	-	ns
	t _{OFF}		-	350	-	ns
	t _{C(OFF)}		-	80	-	ns
	t _{rr}		-	70	-	ns
	I _{rr}		-	6	-	A
Collector - emitter Leakage Current	I _{CES}	V _{CE} = V _{CES}	-	-	250	μA

Note

- t_{ON} and t_{OFF} include the propagation delay time of the internal drive IC. t_{C(ON)} and t_{C(OFF)} are the switching time of IGBT itself under the given gate driving condition internally. For the detailed information, please see Fig. 4

Electrical Characteristics

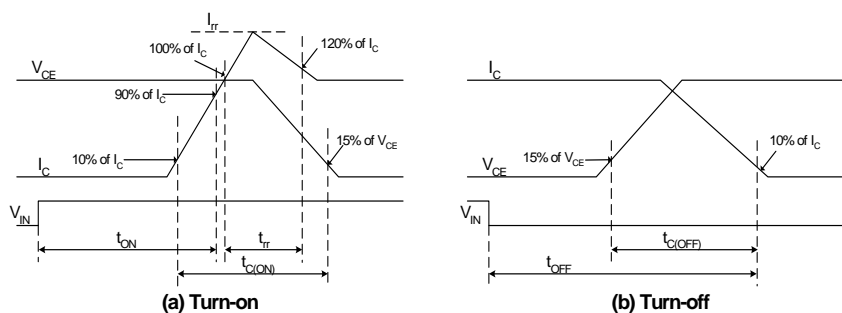

Fig. 4. Switching Time Definition

Control Part

Item	Symbol	Condition	Min.	Typ.	Max.	Unit
Quiescent V _{CC} Supply Current	I _{QCCL}	V _{CC} = 15 V, I _N = 0 V V _{CC} - COM	-	-	26	mA
Fault Output Voltage	V _{FOH}	V _{SC} = 0 V, V _{FO} Circuit: 4.7 kΩ to 5 V Pull-up	4.5	-	-	V
	V _{FOL}	V _{SC} = 1 V, V _{FO} Circuit: 4.7 kΩ to 5 V Pull-up	-	-	0.8	V
Over Current Trip Level	V _{SC(ref)}	V _{CC} = 15 V	0.45	0.5	0.55	V
Supply Circuit Under-Voltage Protection	UV _{CCD}	Detection Level	10.7	11.9	13.0	V
	UV _{CCR}	Reset Level	11.2	12.4	13.2	V
Fault-out Pulse Width	t _{FOD}	C _{FOD} = 33 nF (Note 2)	1.4	1.8	2.0	ms
ON Threshold Voltage	V _{IN(ON)}	Applied between IN - COM	2.8	-	-	V
OFF Threshold Voltage	V _{IN(OFF)}		-	-	0.8	V
Resistance of Thermistor	R _{TH}	@ T _{TH} = 25°C (Note3, Fig. 9)	-	47.0	-	kΩ
		@ T _{TH} = 100°C (Note3, Fig. 9)	-	2.9	-	kΩ

Note

- The fault-out pulse width t_{FOD} depends on the capacitance value of C_{FOD} according to the following approximate equation : C_{FOD} = 18.3 × 10⁻⁶ × t_{FOD}[F]
- T_{TH} is the temperature of thermistor itself. To know case temperature (T_C), please make the experiment considering your application.

Recommended Operating Condition

Item	Symbol	Condition	Min.	Typ.	Max.	Unit
Input Supply Voltage	V_i	Applied between R-S	187	220	253	V
Output Voltage	V_{PN}	Applied between P-N		380	400	V
Control Supply Voltage	V_{CC}	Applied between $V_{CC(L)}$ - COM	13.5	15	16.5	V
Control supply variation	dV_{CC}/dt		-1	-	1	V/ μ s
PWM Input Frequency	f_{PWM}	$T_J \leq 150^\circ\text{C}$ per IGBT		20		kHz
Allowable Input Current (Peak)	I_i	$T_C < 95^\circ\text{C}$, $V_i = 220\text{ V}$, $V_{PN} = 380\text{ V}$ $V_{PWM} = 20\text{ kHz}$			20	A

Mechanical Characteristics and Ratings

Item	Condition	Limit			Unit
		Min.	Typ.	Max.	
Mounting Torque	Mounting Screw: M3 Recommended 0.62 N•m	0.51	0.62	0.72	N•m
Device Flatness	Note Fig. 5	0	-	+120	μ m
Weight		-	15.00	-	g

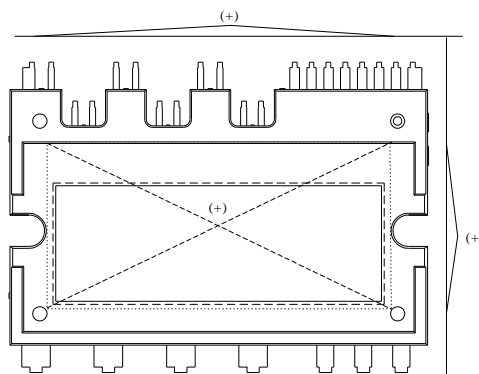
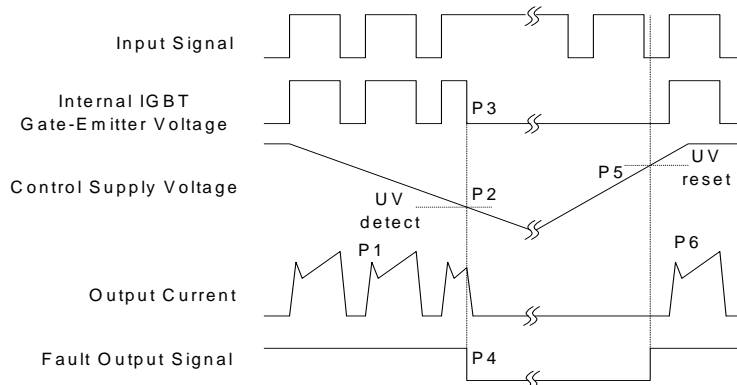

Fig. 5. Flatness Measurement Position

Time Charts of SPMs Protective Function



- P1 : Normal operation - IGBT ON and conducting current
- P2 : Under voltage detection
- P3 : IGBT gate interrupt
- P4 : Fault signal generation
- P5 : Under voltage reset
- P6 : Normal operation - IGBT ON and conducting current

Fig. 6. Under-Voltage Protection

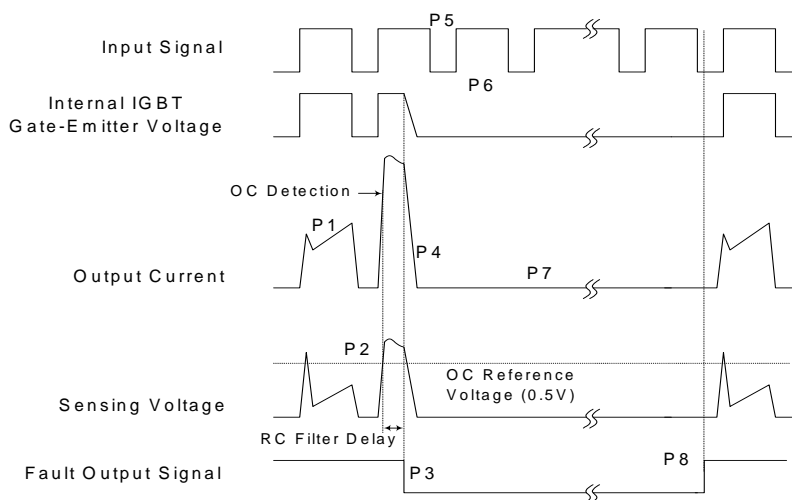

- P1 : Normal operation - IGBT ON and conducting current
- P2 : Over current detection
- P3 : IGBT gate interrupt / Fault signal generation
- P4 : IGBT is slowly turned off
- P5 : IGBT OFF signal
- P6 : IGBT ON signal - but IGBT cannot be turned on during the fault Output activation
- P7 : IGBT OFF state
- P8 : Fault Output reset and normal operation start

Fig. 7. Over Current Protection

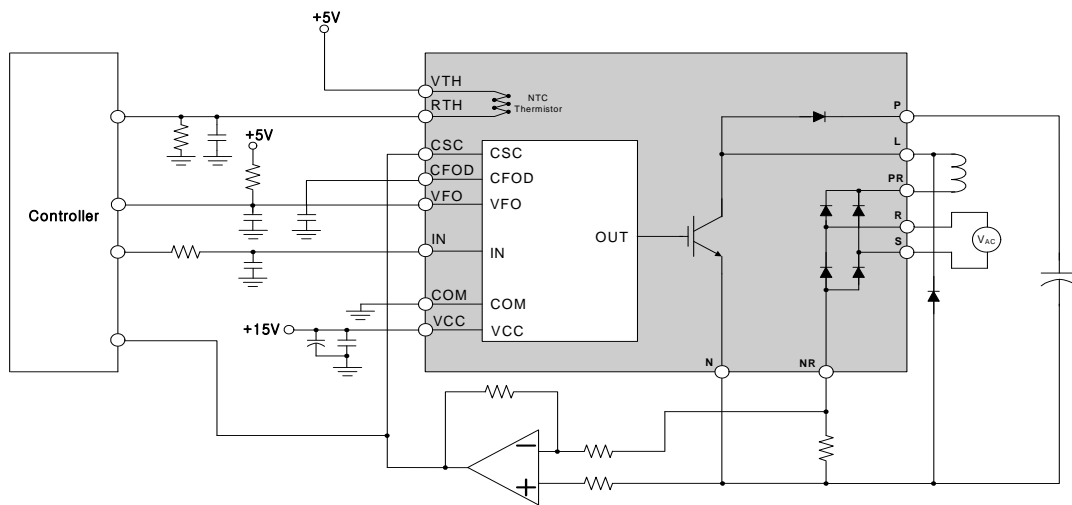

Note:

1. Each capacitors should be located as close to PFC SPM® product pins as possible.
2. It's recommended that anti-parallel diode should be connected with IGBT.

Fig. 8. Application Example

R-T Curve

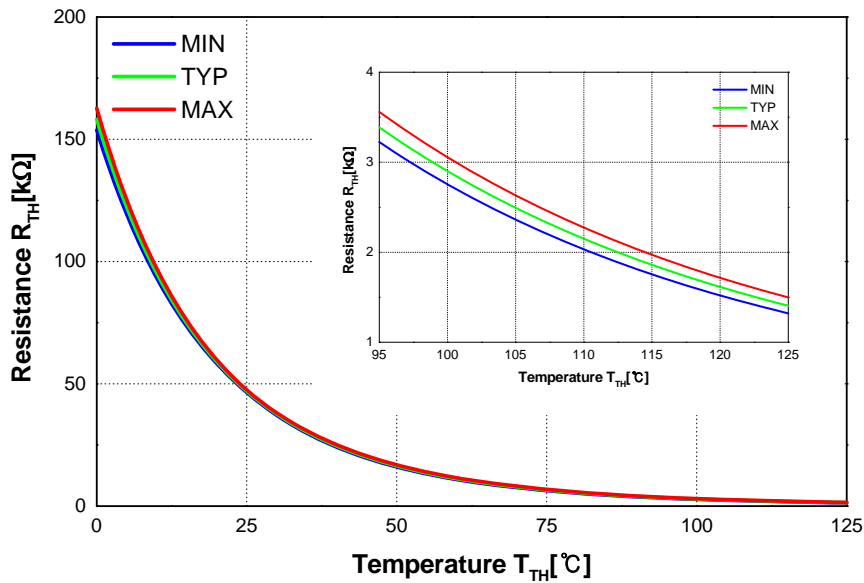
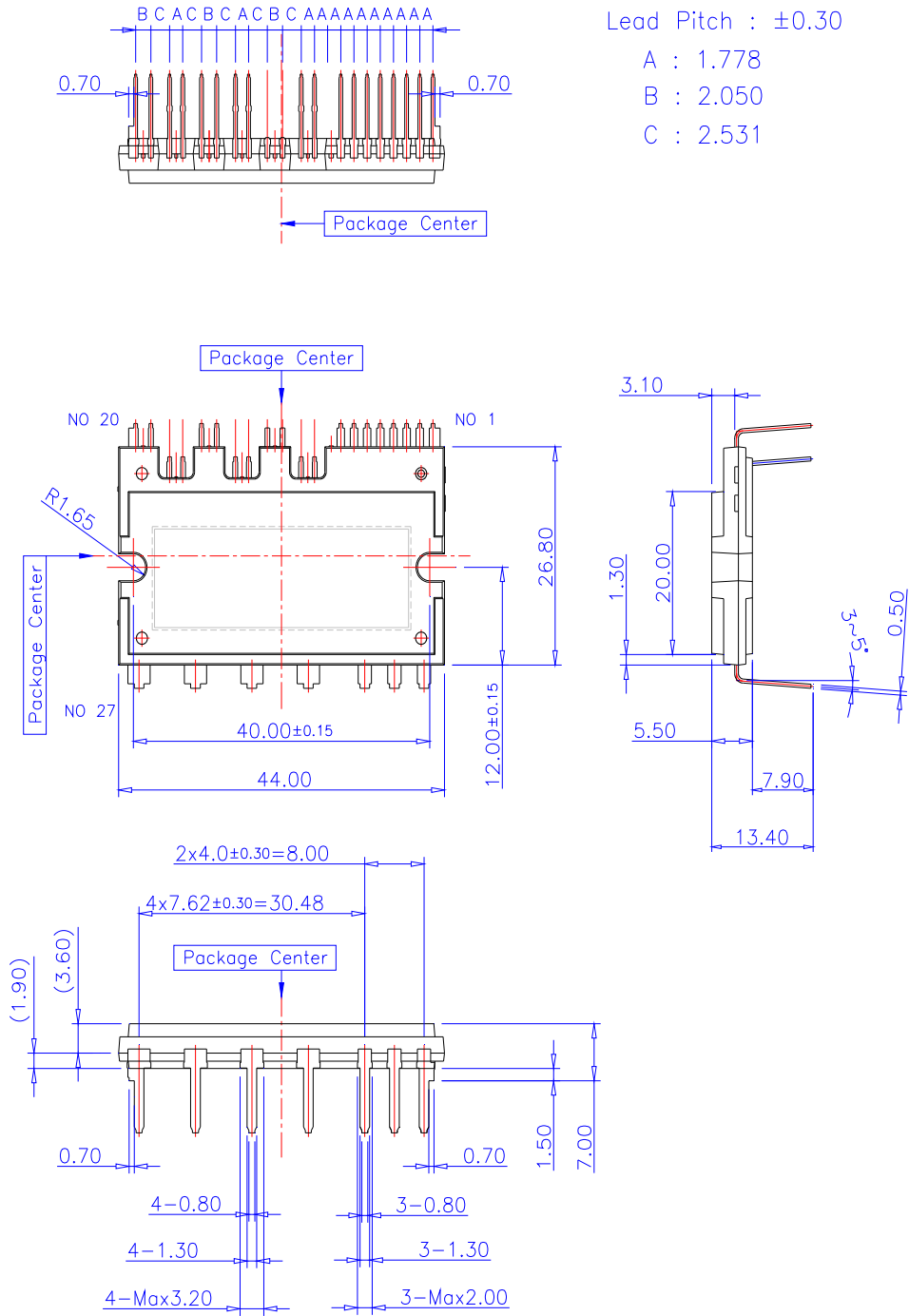
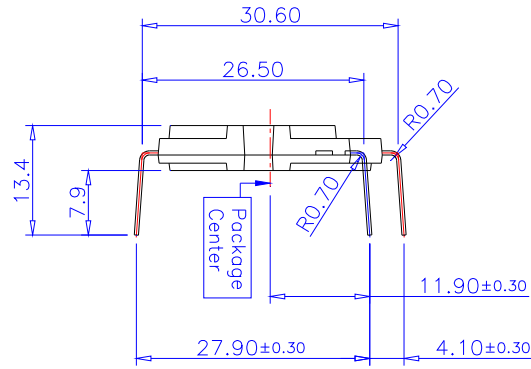

Fig. 9. R-T Curve of the Built-in Thermistor

Detailed Package Outline Drawings



Detailed Package Outline Drawings



Lead Forming Dimension

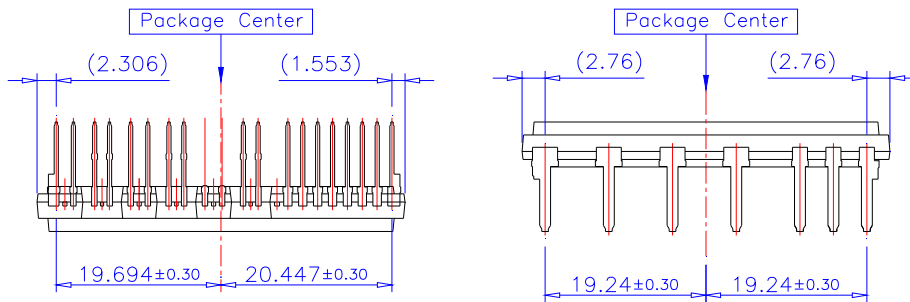

PKG Center to Lead Distance

Detailed Package Outline Drawings

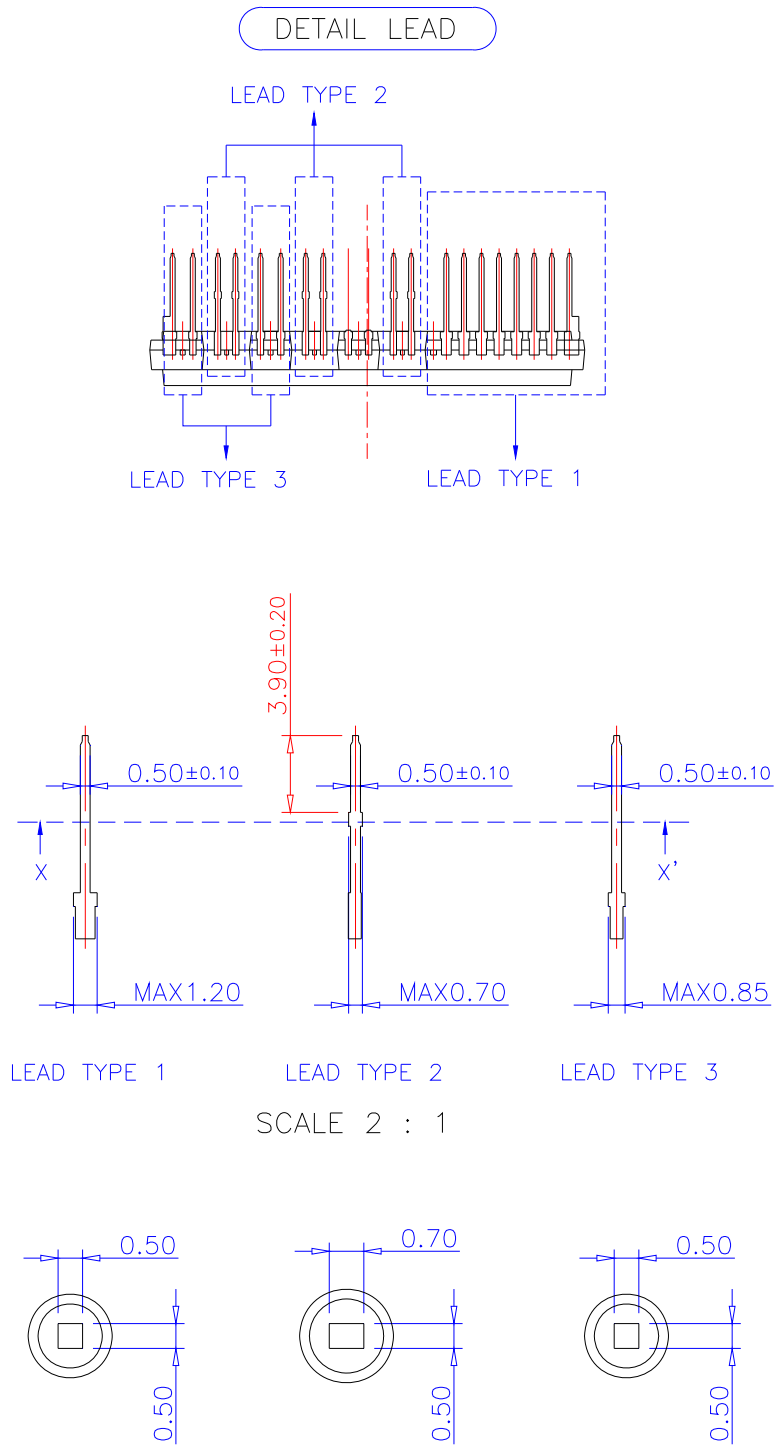



TRADEMARKS

The following includes registered and unregistered trademarks and service marks, owned by Fairchild Semiconductor and/or its global subsidiaries, and is not intended to be an exhaustive list of all such trademarks.

2Cool™	FPST™		Sync-Lock™
AccuPower™	F-PFST™	PowerTrench®	 SYSTEM GENERAL®
AX-CAP®*	FRFET®	PowerXS™	TinyBoost™
BitSiC™	Global Power Resource SM	Programmable Active Droop™	TinyBuck™
Build it Now™	GreenBridge™	QFET®	TinyCalc™
CorePLUSTM	Green FPS™	QST™	TinyLogic®
CorePOWER™	Green FPS™ e-Series™	Quiet Series™	TINYOPTO™
CROSSVOL7™	Gmax™	RapidConfigure™	TinyPower™
CTL™	GTO™	 ™	TinyPWM™
Current Transfer Logic™	IntelliMAX™	Saving our world, 1mW/W at a time™	TinyWire™
DEUXPEED®	ISOPLANAR™	SignalWise™	TransiC™
Dual Cool™	Making Small Speakers Sound Louder and Better™	SmartMax™	TriFault Detect™
EcoSPARK®	MegaBuck™	SMART START™	TRUECURRENT®*
EfficientMax™	MICROCOUPLER™	Solutions for Your Success™	µSerDes™
ESBC™	MicroFET™	SPM®	 SerDes™
 Fairchild®	MicroPak™	STEALTH™	UHC®
Fairchild Semiconductor®	MicroPak2™	SuperFET®	Ultra FRFET™
FACT Quiet Series™	MillerDrive™	SuperSOT™.3	UniFET™
FACT®	MotionMax™	SuperSOT™.6	Vcx™
FAST®	mWSaver™	SuperSOT™.8	VisualMax™
FastvCore™	OptoHiT™	SupreMOS®	VoltagePlus™
FETBench™	OPTOLOGIC®	SyncFET™	XS™
	OPTOPLANAR®		

* Trademarks of System General Corporation, used under license by Fairchild Semiconductor.

DISCLAIMER

FAIRCHILD SEMICONDUCTOR RESERVES THE RIGHT TO MAKE CHANGES WITHOUT FURTHER NOTICE TO ANY PRODUCTS HEREIN TO IMPROVE RELIABILITY, FUNCTION, OR DESIGN. FAIRCHILD DOES NOT ASSUME ANY LIABILITY ARISING OUT OF THE APPLICATION OR USE OF ANY PRODUCT OR CIRCUIT DESCRIBED HEREIN; NEITHER DOES IT CONVEY ANY LICENSE UNDER ITS PATENT RIGHTS, NOR THE RIGHTS OF OTHERS. THESE SPECIFICATIONS DO NOT EXPAND THE TERMS OF FAIRCHILD'S WORLDWIDE TERMS AND CONDITIONS, SPECIFICALLY THE WARRANTY THEREIN, WHICH COVERS THESE PRODUCTS.

LIFE SUPPORT POLICY

FAIRCHILD'S PRODUCTS ARE NOT AUTHORIZED FOR USE AS CRITICAL COMPONENTS IN LIFE SUPPORT DEVICES OR SYSTEMS WITHOUT THE EXPRESS WRITTEN APPROVAL OF FAIRCHILD SEMICONDUCTOR CORPORATION.

As used herein:

1. Life support devices or systems are devices or systems which, (a) are intended for surgical implant into the body or (b) support or sustain life, and (c) whose failure to perform when properly used in accordance with instructions for use provided in the labeling, can be reasonably expected to result in a significant injury of the user.
2. A critical component in any component of a life support, device, or system whose failure to perform can be reasonably expected to cause the failure of the life support device or system, or to affect its safety or effectiveness.

ANTI-COUNTERFEITING POLICY

Fairchild Semiconductor Corporation's Anti-Counterfeiting Policy. Fairchild's Anti-Counterfeiting Policy is also stated on our external website, www.fairchildsemi.com, under Sales Support.

Counterfeiting of semiconductor parts is a growing problem in the industry. All manufacturers of semiconductor products are experiencing counterfeiting of their parts. Customers who inadvertently purchase counterfeit parts experience many problems such as loss of brand reputation, substandard performance, failed applications, and increased cost of production and manufacturing delays. Fairchild is taking strong measures to protect ourselves and our customers from the proliferation of counterfeit parts. Fairchild strongly encourages customers to purchase Fairchild parts either directly from Fairchild or from Authorized Fairchild Distributors who are listed by country on our web page cited above. Products customers buy either from Fairchild directly or from Authorized Fairchild Distributors are genuine parts, have full traceability, meet Fairchild's quality standards for handling and storage and provide access to Fairchild's full range of up-to-date technical and product information. Fairchild and our Authorized Distributors will stand behind all warranties and will appropriately address any warranty issues that may arise. Fairchild will not provide any warranty coverage or other assistance for parts bought from Unauthorized Sources. Fairchild is committed to combat this global problem and encourage our customers to do their part in stopping this practice by buying direct or from authorized distributors.

PRODUCT STATUS DEFINITIONS

Definition of Terms

Datasheet Identification	Product Status	Definition
Advance Information	Formative / In Design	Datasheet contains the design specifications for product development. Specifications may change in any manner without notice.
Preliminary	First Production	Datasheet contains preliminary data; supplementary data will be published at a later date. Fairchild Semiconductor reserves the right to make changes at any time without notice to improve design.
No Identification Needed	Full Production	Datasheet contains final specifications. Fairchild Semiconductor reserves the right to make changes at any time without notice to improve the design.
Obsolete	Not In Production	Datasheet contains specifications on a product that is discontinued by Fairchild Semiconductor. The datasheet is for reference information only.

Rev. I64