

MODEL BMK3 & BMK4 - BASE MOUNT KITS

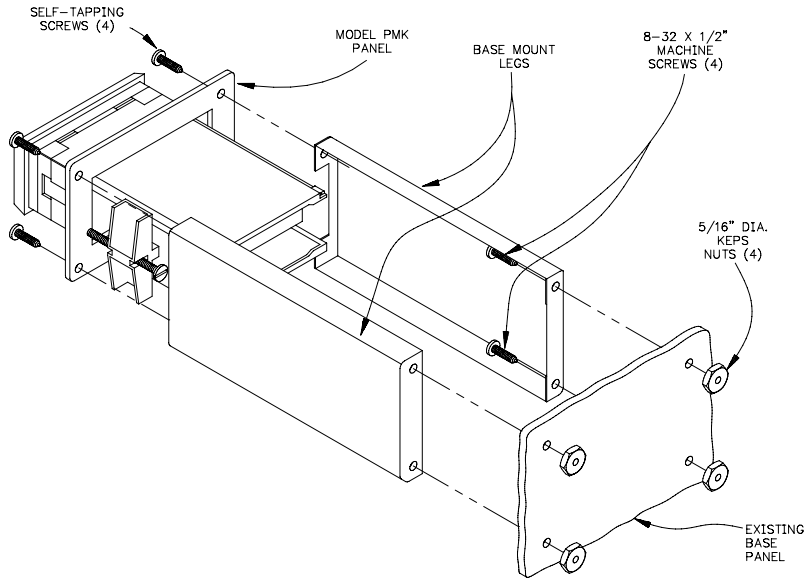

DESCRIPTION

The Model BMK3 and 4 Base Mount Kits provide the necessary equipment for base mounting various units. The kits are coated with a durable flat black polyurethane finish and consist of two mounting legs which attach to the customer's base panel, using the hardware provided.

Model PMK3 and 4 are separate front panels, available for different sized units. After mounting the units to the appropriate PMK panel, the entire assembly is then attached to the mounting legs.

MOUNTING PROCEDURE

1. Mark and drill holes ($3/16"$ Dia.) in base panel for attaching the base mount legs. Use the appropriate Model PMK panel as a template for marking the mounting hole locations. NOTE: RECOMMENDED MINIMUM BASE PANEL THICKNESS IS $1/8"$ TO SUPPORT THE WEIGHT OF THE INDICATOR WITHOUT PANEL DISTORTION.
2. Attach the base mount legs to the base panel using the machine screws and nuts provided or user supplied hardware if panel thickness exceeds $1/4"$.
3. Mount the indicator to the Model PMK panel, utilizing the mounting clips provided, in accordance with the panel mounting instructions supplied with the individual unit.
4. Attach the PMK panel and unit assembly to the base mount legs by using the self-tapping screws provided.

BASE MOUNT DIMENSIONS In inches (mm)

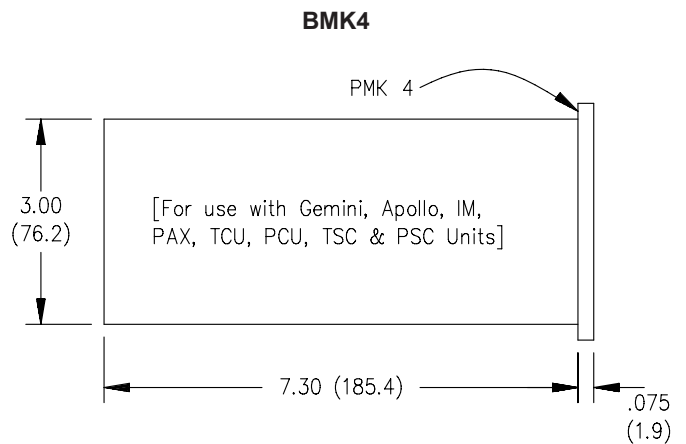
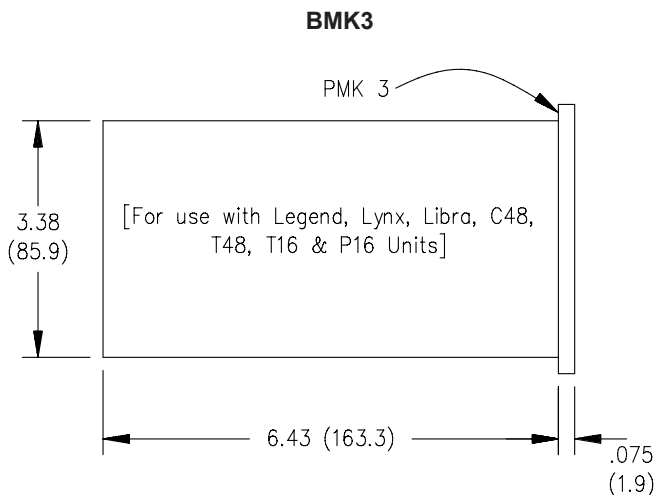

PANEL DIMENSIONS In inches (mm)

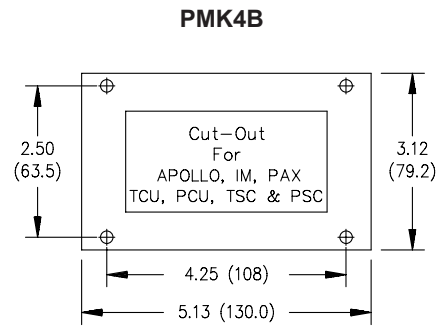
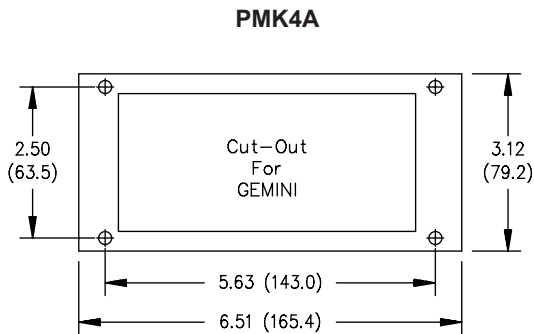
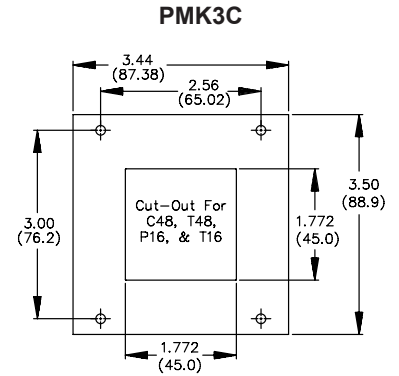
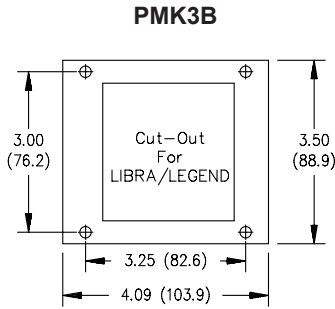
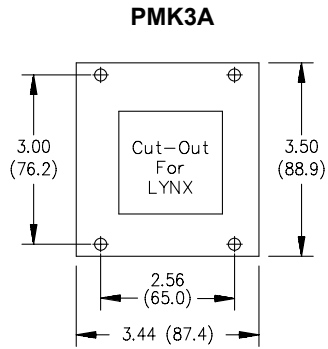

ORDERING INFORMATION

MODEL NO.	DESCRIPTION	PART NUMBER
BMK 3	Base Mount Kit For Legend, Lynx And Libra	BMK30000
BMK 4	Base Mount Kit For Gemini, Apollo, IM, PAX, TCU, PCU, TSC And PSC	BMK40000
PMK 3A	Mounting Panel For Lynx	PMK3A000
PMK 3B	Mounting Panel For Libra And Legend	PMK3B000
PMK 3C	Mounting Panel For C48, T48, P16 And T16	PMK3C000
PMK 4A	Mounting Panel For Gemini	PMK4A000
PMK 4B	Mounting Panel For IM, Apollo, PAX, TCU, PCU, TSC And PSC	PMK4B000

Red Lion Controls
20 Willow Springs Circle
York PA 17406
Tel +1 (717) 767-6511
Fax +1 (717) 764-0839

Red Lion Controls BV
Printerweg 10
NL - 3821 AD Amersfoort
Tel +31 (0) 334 723 225
Fax +31 (0) 334 893 793

Red Lion Controls AP
31, Kaki Bukit Road 3,
#06-04/05 TechLink
Singapore 417818
Tel +65 6744-6613
Fax +65 6743-3360