

Panasonic
ideas for life

Load current 15 to 40A
Small Screw Terminal SSR

AQ-A RELAYS

New



RoHS compliant

FEATURES

- 1. Compact Size**
W 40 × L 58 × H 25.5 mm
W 1.575 × L 2.283 × H 1.004 inch
- 2. With terminal cover for safety (output side only).**
* Cover on input side available as option.
- 3. Mounting pitch 47.5 mm 1.870 inch**
- 4. Built in varistor for excellent surge absorption**
- 5. With LED indication for operation status verification**

TYPICAL APPLICATIONS

- Heater control
- **Business use:**
Cooking machine, Vending machine, Freezer and Refrigerator
 - **Industrial use:**
Molding machine, Temperature controlled bath, Printing machine and Packing machine

ORDERING INFORMATION

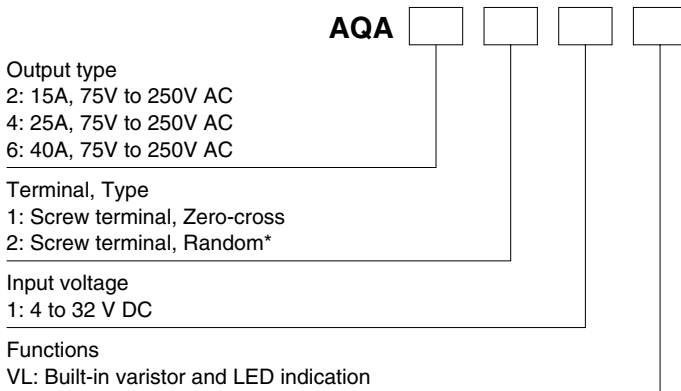

* Random type is available by custom order.

TYPES

1. AQ-A Solid State Relays

Type	Load current	Load voltage	Input voltage	Part No.
Zero-cross	15A	75V to 250V AC	4 to 32V DC	AQA211VL
	25A			AQA411VL
	40A			AQA611VL

Standard Packing: carton: 2 pcs., case: 60 pcs.
Note: Random type also available. Please inquire.

2. Accessories

Type	Part No.	Packaged quantity
Standard heat sink (15A)	AQP-HS-J10A	5 in a carton, 20 in a case
Standard heat sink (25A)	AQP-HS-30/40A	5 in a carton, 20 in a case
Standard heat sink (40A)	AQP-HS-J25A	No carton, 5 in a case
Slim heat sink (45mm wide) (Mountable on a DIN rail)	AQP-HS-SJ20A	No carton, 8 in a case
DIN rail mounting plate	AQP-DPJ	No carton, 50 in a case
Terminal cover	AQA801	—

AQ-A

RATING

1. Ratings (Measurement condition: at 20°C 68°F, Input ripple: 1% or less)

Item	Part No.	AQA211VL	AQA411VL	AQA611VL	Remarks
Input side	Input voltage	4 to 32V DC			
	Input current	Max. 20mA			
	Drop-out voltage	Min. 1V			
Output side	Max. load current	15A	25A	40A	In one cycle at 60Hz at 60Hz at Max. carrying current
	Load voltage	75 to 250V AC			
	Frequency	45 to 65Hz			
	Non-repetitive surge current	150A	250A	400A	
	"OFF-state" leakage current	Max. 10mA			
	"ON-state" voltage drop	Max. 1.6V			
	Min. load current*	100mA			

Note: * When the load current is less than the rated minimum load current, please refer to "Cautions for Use".

2. Characteristics (Measurement condition: at 20°C 68°F, Input ripple: 1% or less)

Item	AQA211VL	AQA411VL	AQA611VL	Remarks
Operate time	Max. 1/2 cycle of voltage sine wave + 1ms			
Release time	Max. 1/2 cycle of voltage sine wave + 1ms			
Insulation resistance	Min. 100MΩ between input and output			at 500 V DC
Breakdown voltage	4,000 Vrms between input and output 2,500 Vrms between input, output and case			for 1min.
Vibration resistance (Functional)	10 to 55Hz double amplitude of 1.5mm			X, Y, Z axes
Shock resistance (Functional)	Min. 980 m/s ²			X, Y, Z axes
Ambient temperature	-20°C to +80°C -4°F to +176°F			Non-condensing at low temperatures
Storage temperature	-20°C to +85°C -4°F to +185°F			Non-condensing at low temperatures
Operational method	Zero-cross (Turn ON and Turn OFF)			

REFERENCE DATA

1. Load current vs. ambient temperature

Use load current within range specified in the figure below.

Tested condition

With external heat sink

- 1) (1) When using standard heat sink (AQP-HS-J25A)
- (2) When using standard heat sink (AQP-HS-30/40A)
- (3) When using standard heat sink (AQP-HS-J10A)
- (4) When using standard heat sink (AQP-HS-SJ20A)
- 2) If attached to a heat sink, use a heat conductive compound (Ex. Momentive Performance Materials Inc. YG6111 or TSK5303) of similar coating to improve cooling.

Without external heat sink

If the mounting surface is not metallic and a heat sink is not used, expose the bottom surface and plate surface to improve heat dissipation.

(1) 15A type (AQA211VL)

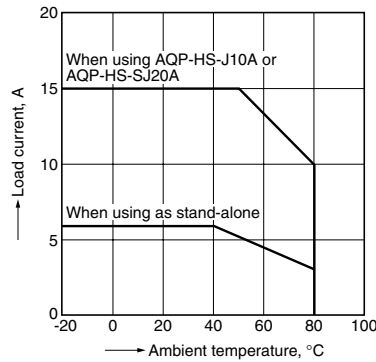

(2) 25A type (AQA411VL)

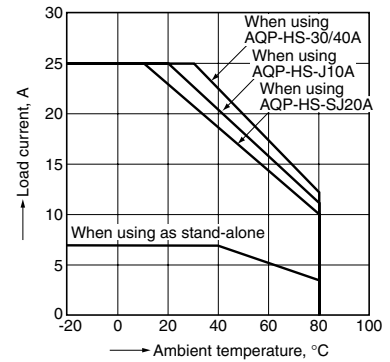

(3) 40A type (AQA611VL)

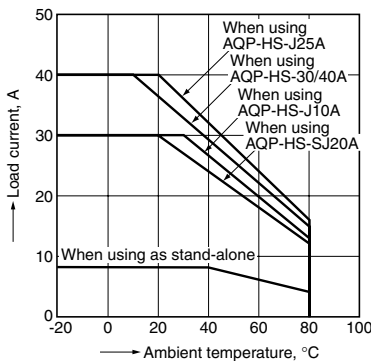

2. Non-repetitive surge current vs. carrying time characteristics

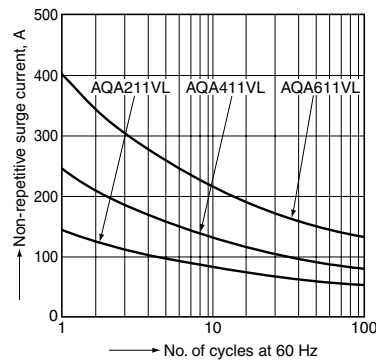

3. Input current vs. input voltage characteristics

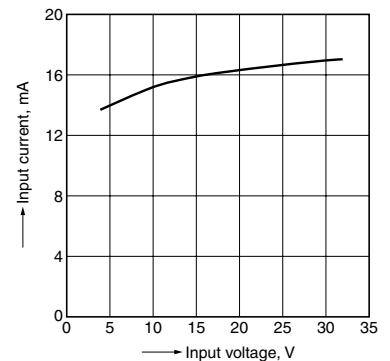

DIMENSIONS (mm inch)

The CAD data of the products with a **CAD Data** mark can be downloaded from: <http://industrial.panasonic.com/ac/e/>

CAD Data



External dimensions

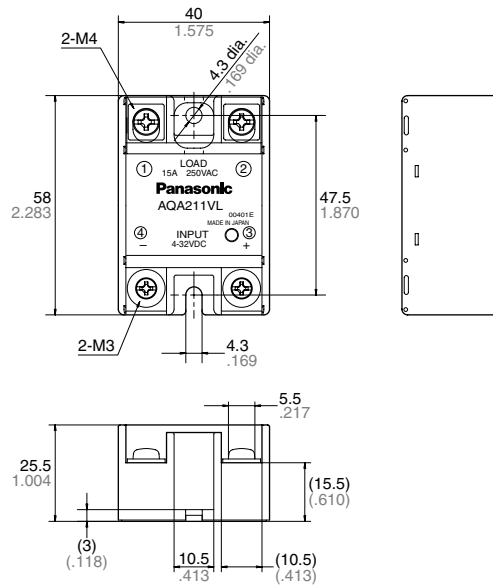

Schematic

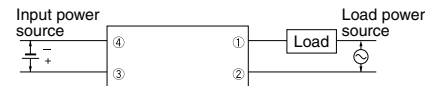

Mounting dimensions

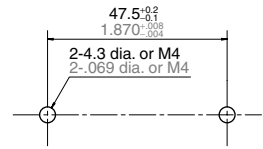

ACCESSORIES (mm inch)

AQP-HS-SJ20A Slim Heat Sink

CAD Data



External dimensions

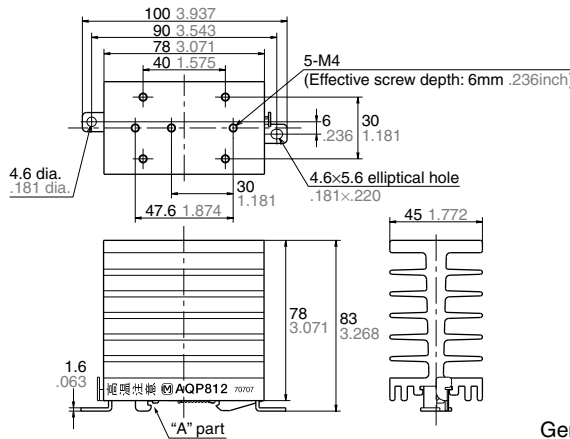

Mounting dimensions

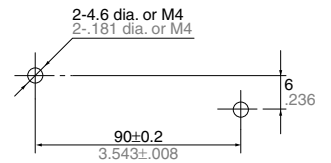

Note: When using on a DIN rail, please install so that the "A" part is on top.

General tolerance: ±1.0 ±.039

AQP-HS-J10A Standard Heat Sink

CAD Data



External dimensions

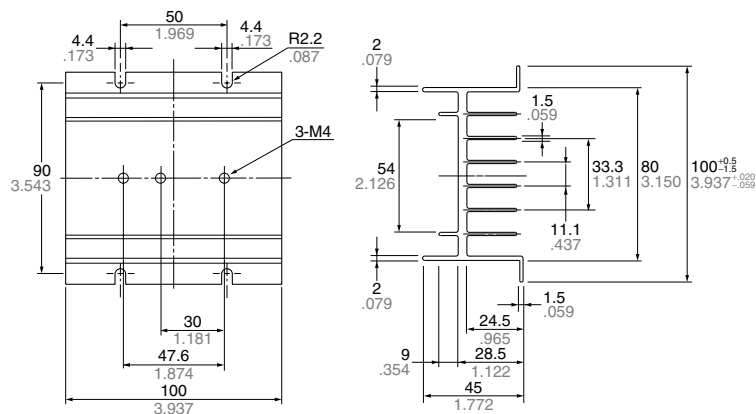

Mounting dimensions

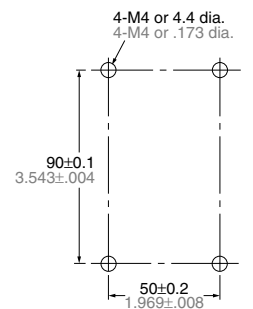

AQ-A

AQP-HS-30/40A Standard Heat Sink

External dimensions

Mounting dimensions

CAD Data

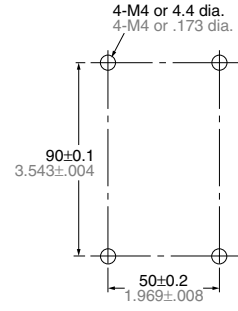
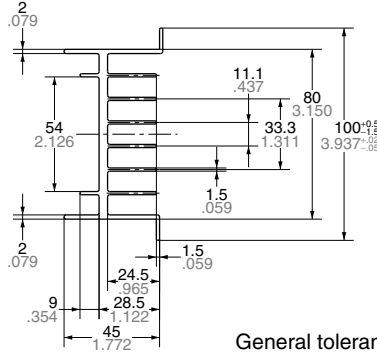
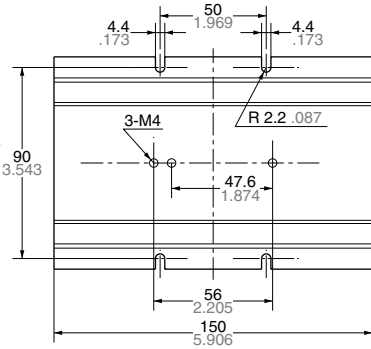

General tolerance: $\pm 0.5 \pm 0.020$

AQP-HS-J25A Standard Heat Sink

External dimensions

Mounting dimensions

CAD Data

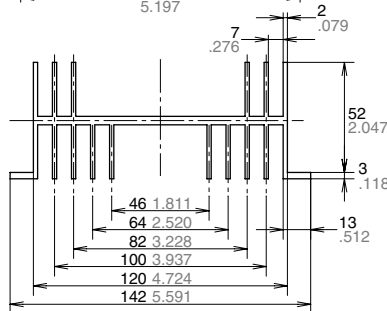
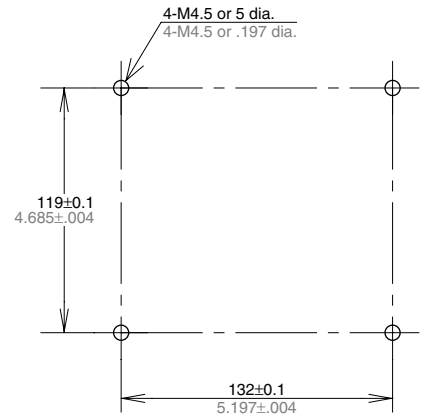
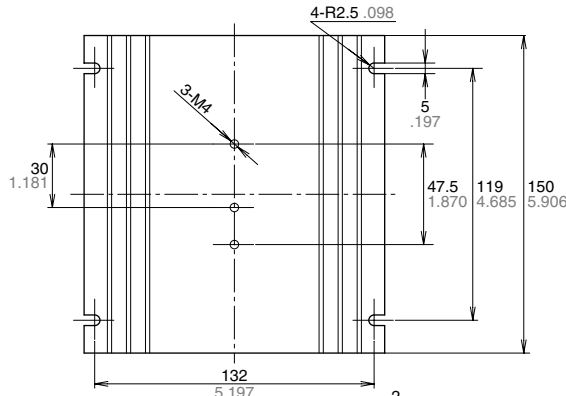
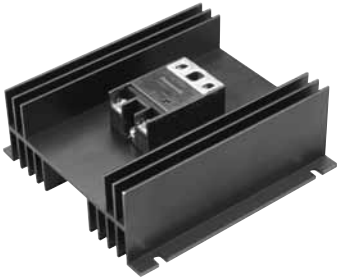

AQP-DPJ DIN Rail Mounting Plate

AT8-DLA1 Mounting Rail

CAD Data

CAD Data

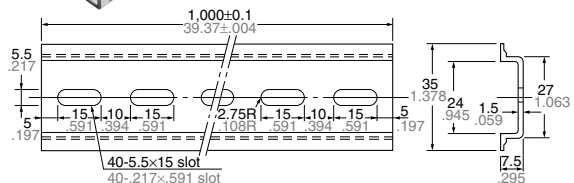
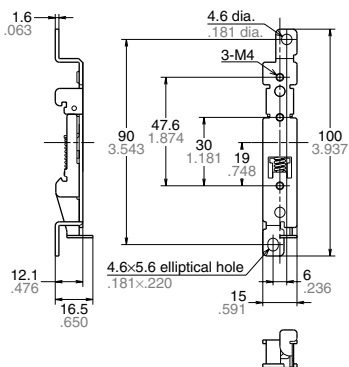

ATA4806 Fastening plate

CAD Data

