



Chicago Miniature Lighting, LLC

Lighting the world since 1910

2150QA and 2151QA Series
Non-Relampable Neon Indicator Lights

2150QA and 2151QA Series Non-Relampable Neon Indicator Lights

DESCRIPTION AND FEATURES

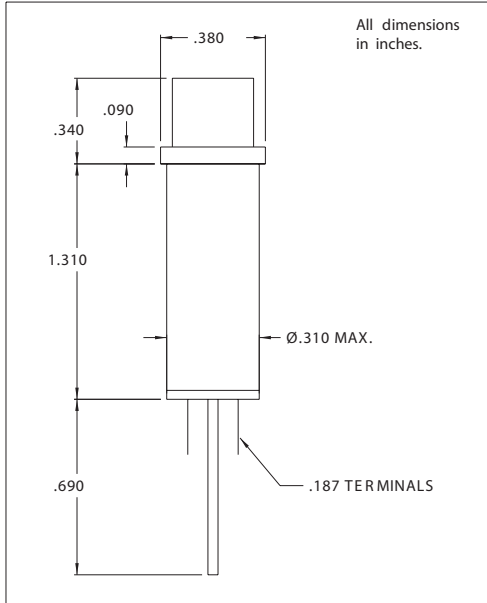

Mounting: Ø.310 MIN., supplied with push-on speednut SN1287.

Terminals: Quick-connect, tinned brass, .187 x .020

Lens: Polycarbonate

Bezel: Polished stainless steel. For black finish add "X" after the series letter(s).

Housing: White Nylon

Lens Color	Neon	
	Model No. (105-125VAC)	Model No. (208-250VAC)
Red	2150QA1	2151QA1
Amber	2150QA3	2151QA3
White	2150QA4	2151QA4
Green	2152QA5*	2153QA5*
Lamp	C2A+R resistor	C2A+R resistor

* Incorporates G2B lamp and resistor.
 Underwriters Laboratories (UL) File No. E20325
 Canadian Standards Association (CSA) File No. LR13346

147 Central Avenue
 Hackensack, NJ 07601
 Phone: (201) 489-8989
 Fax: (201) 489-6911

18703 Dix Toledo Road
 Brownstown, MI 48193

Saret Zone Franca, Edificio B
 Alajuela Costa Rica

E-mail: sales@chml.com • Web Site: www.chml.com

Chicago Miniature Lighting, LLC reserves the right to make specification revisions that enhance the design and/or performance of the product