

ITEM	Q'TY	PART NUMBER	PART DESCRIPTION
1	1	PM3-PL	3mm Polycarbonate Panel Mount Housing
2	1	PM3-FP22	2.2mm to 3mm Flexible Light Pipe Adapter
3	1	PM3-KN	3mm Quick Nut
4	1	FLPS1522-XX.X	1.5mm x 2.2mm Flexible Light Pipe

REV.	DESCRIPTION	DATE	APPROVED
B	Engineering Release	06/19/12	T. Y.

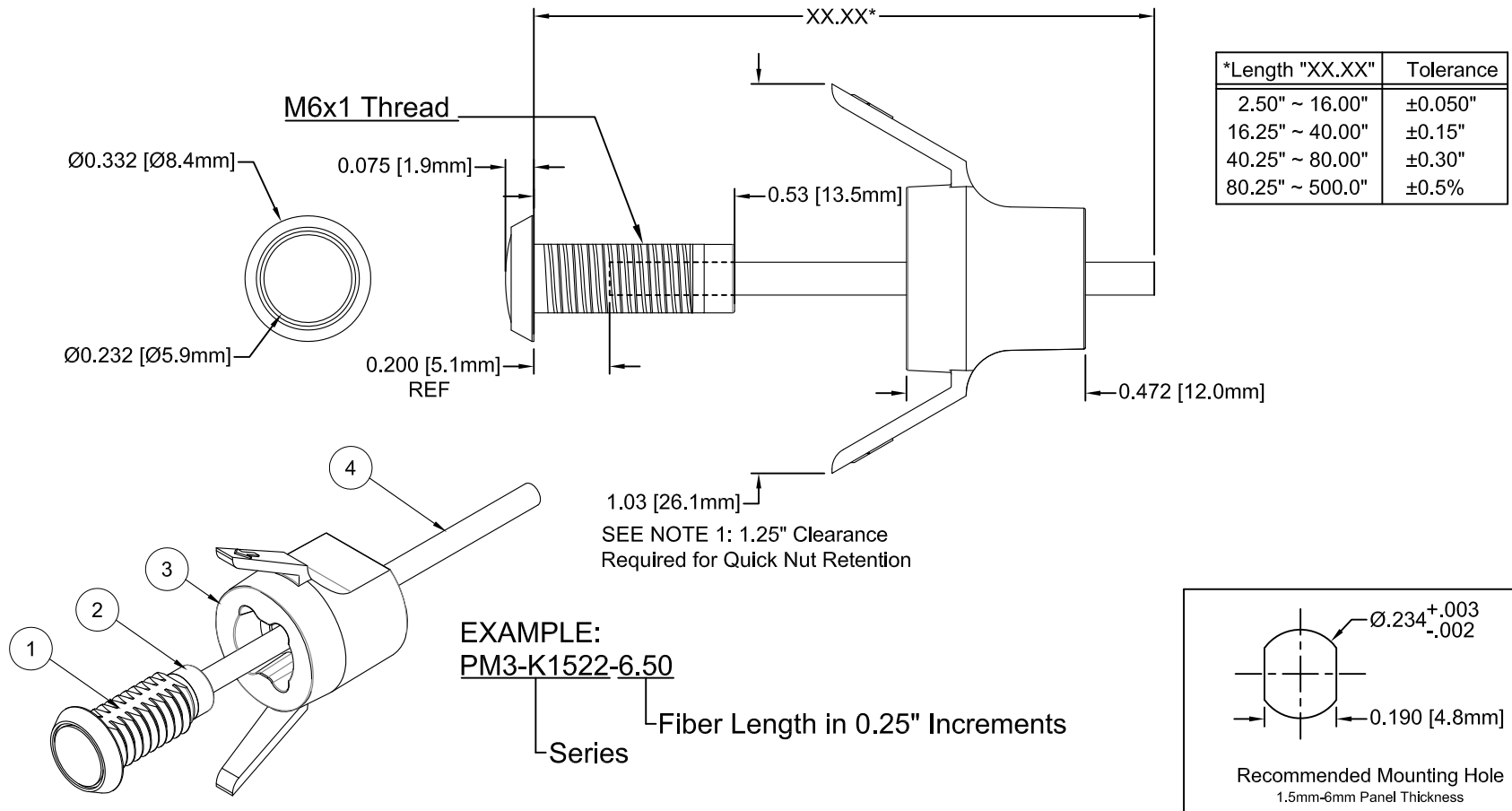

NOTES:

1. TO INSTALL, INSERT HOLDER THROUGH PANEL, PRESS QUICK NUT ON TO HOLDER AS SHOWN. TABS WILL DEFORM FOR RETENTION.
2. ROHS COMPLIANT
3. MOUNTING HARDWARE SHIPPED NON-ASSEMBLED
4. TO REMOVE, TWIST QUICK NUT 90° AND PULL

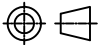
STANDARD TOLERANCE (UNLESS OTHERWISE SPECIFIED)		BIVAR [®] 4 THOMAS, IRVINE, CA. 92618 TEL: (949) 951-8808 FAX: (949) 951-3974
DECIMALS	ANGULAR	
.X ±.1	X° ± 1°	TITLE: Quick-Mount Panel Mount Flexible Light Pipe Indicator PART NO: PM3-K1522-XX.XX REVISION: B
.XX ±.02		
.XXX ±.010		DESIGNED: Brian Oliver DATE: 04/12/12 CHECKED: T. Yin DATE: 04/12/12
		CAGE CODE : 32559 SHEET # 1 OF 1 <small>CAD GENERATED DOCUMENT, DO NOT MEASURE DRAWING.</small>