

SynJet[®] Outdoor Electronics Cooler L100-90

SynJet cooling provides the most reliable thermal management solution available. This LED cooler has been developed by Nuventix for cooling Industrial, Telecom, and other electronic systems.

- Cools up to 53 W⁴
- Reliable 100K Hours Lifetime
- Outdoor Rated (IP56)⁷
- 5 Yr Warranty
- Small Form Factor
- Quiet Acoustics

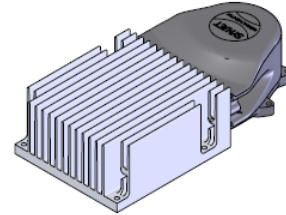

Specifications¹

Thermal & Acoustic

| SynJet Setting ² | Θ_{s-a} ³ AI | TDP ⁴ (W) $\Delta T = 30^\circ / 40^\circ C$ | SPL (dBA) ⁵ | Wire Connections |
|-----------------------------|-----------------------------------|--|---------------------------|---|
| High Performance | 0.75 | 40 / 53 | 29 | Red to +VDC Black & Blue to Ground |
| PWM at 100% duty cycle | 0.75 | 40 / 53 | 29 | Red to +VDC Black only to Ground Blue to PWM Signal |

Electrical

| SynJet Setting ² | Voltage (VDC) +/- 10% | Current (mA) ⁶ | | | Pavg (mW) | Voltage (VDC) +/- 10% | Current (mA) ⁶ | | | Pavg (mW) |
|-----------------------------|-----------------------------|---------------------------|------|-------|--------------|-----------------------------|---------------------------|------|-------|--------------|
| | | Imin | Iavg | Ipeak | | | Imin | Iavg | Ipeak | |
| High Performance | 5 | 20 | 180 | 360 | 900 | 12 | 10 | 92 | 184 | 1100 |
| PWM at 100% duty cycle | | 20 | 220 | 440 | 1100 | | 10 | 115 | 230 | 1380 |

Environmental

| All Settings | Min | Max | Units | Conditions |
|-----------------------------|-----|------|-------|------------------------------------|
| Operating Temperature | -40 | 70 | °C | Air temperature surrounding cooler |
| Storage Temperature | -50 | 75 | °C | Air temperature surrounding cooler |
| Storage Altitude | | 15K | m | Above sea level |
| Operating Relative Humidity | 5 | 95 | % | Non-condensing |
| Weight | | 400 | g | SynJet with AI heat sink |
| Reliability | | 100K | hrs | L10 @ 60°C |
| Regulatory Compliance | | | | RoHS, UL, FCC Part 15 Class B, CE |

¹ All values are typical at 25°C unless otherwise stated.

² The Level Select model should be used for discrete performance settings. Follow the instructions in the Product Design Guide for adjusting settings.

³ Thermal resistance values are given as reference only and are measured in free air without airflow obstructions. Thermal resistance is measured from the bottom middle of the heat sink to ambient air measured at the inlet to the SynJet, with a heat source at least 15cm² using a reference heat sink. Actual thermal performance may vary by application and final product design should be tested to assure proper thermal performance.

⁴ Thermal Design Power is based on a 30°C or 40°C temperature rise of heat sink mounting surface above ambient temperature around cooler.

⁵ Sound Pressure Level is measured at 1 meter distance per ISO 7779.

⁶ The SynJet has a time varying current. The current waveform is sinusoidal and the average current (Iavg) is used to calculate the average power consumption (Pavg) at nominal input voltage (VDC). See the Electrical section in the Product Design Guide for a detailed explanation.

⁷ SynJet design guidelines for outdoor use must be followed to meet rated lifetime specifications.

PRODUCT DATASHEET

Mechanical

SynJet Cooling Solution shown with Configurable heat sink

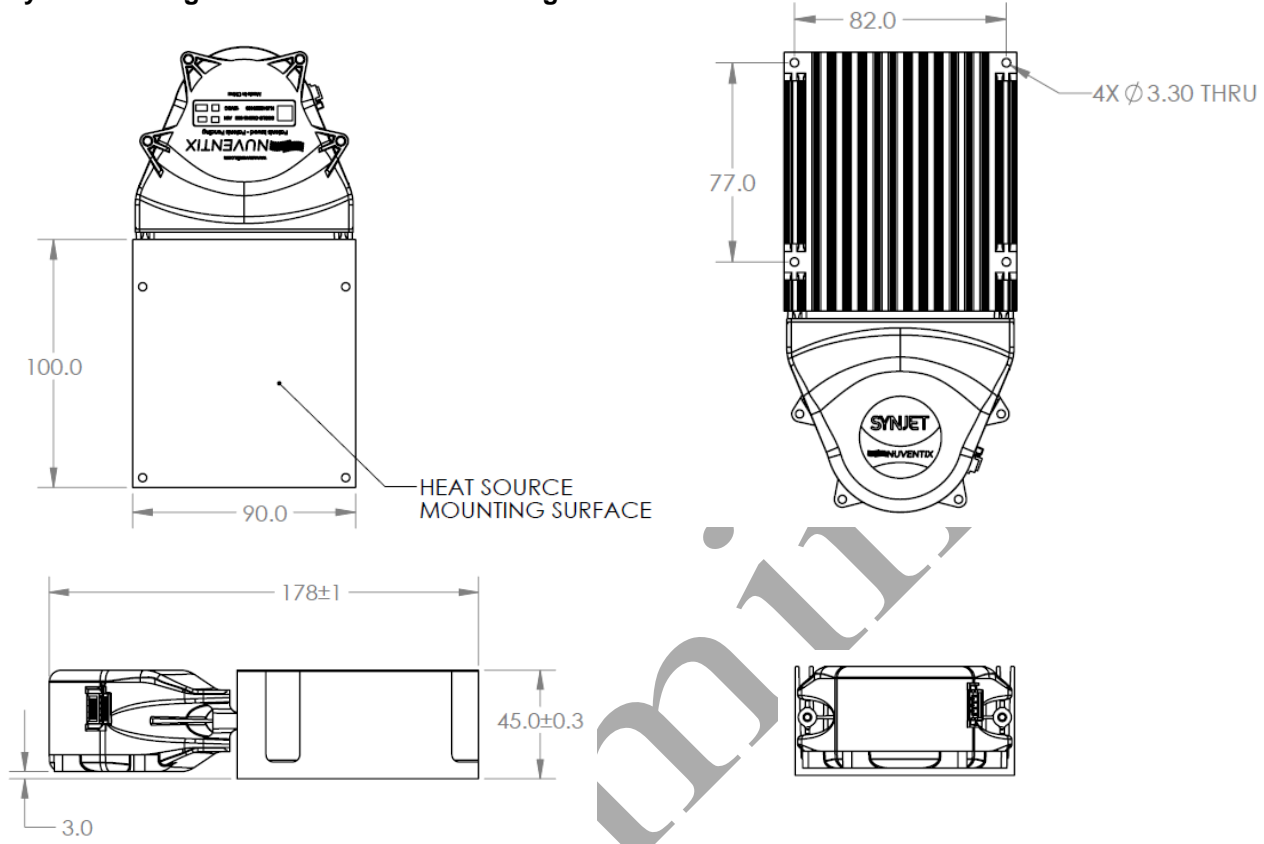

All dimensions are nominal and in mm unless otherwise stated. See product drawings for more detail.

SynJet Wire Harness

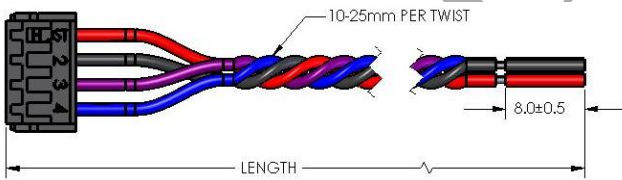

Connector Pinout

| Pin | Wire Color | Symbol | Description |
|-----|------------|--------|---|
| 1 | Red | +VDC | 5 V or 12 V depending on model |
| 2 | Black | GND | Ground |
| 3 | Purple | CTRL2 | Input for Level Select model Status signal for PWM model |
| 4 | Blue | CTRL1 | Input for Level Select model PWM input for PWM model |

IMPORTANT: SynJets should be completely wired to the power supply before the power supply is energized. The power supply should be turned off before the SynJet Cooler is disconnected. SynJet Coolers are not designed for "hot swap" or "hot plug" applications.

Part Numbers

| Part Number | Description | Notes |
|-------------|--|---|
| NX202104 | SynJet, XFlow 42, Outdoor, PWM, 5V, 600mm Wire Harness | Use with PWM input to control performance setting |
| NX202105 | SynJet, XFlow 42, Outdoor, Level Select, 5V, 600mm Wire Harness | Configurable to discrete performance settings |
| NX202106 | SynJet, XFlow 42, Outdoor, PWM, 12V, 600mm Wire Harness | Use with PWM input to control performance setting |
| NX202107 | SynJet, XFlow 42, Outdoor, Level Select, 12V, 600mm Wire Harness | Configurable to discrete performance settings |
| NX302101 | Heatsink, Electronics Cooler L100-90, Configurable, Black | Contact sales for other heatsink options |

Nuventix reserves the right to make changes to the products or information contained herein without notice. No liability is assumed as a result of their use or applications. For additional information, please contact Nuventix directly.