

REV.	DESCRIPTION	DATE	APPROVED
B	Engineering Release	03/15/12	T. Y.

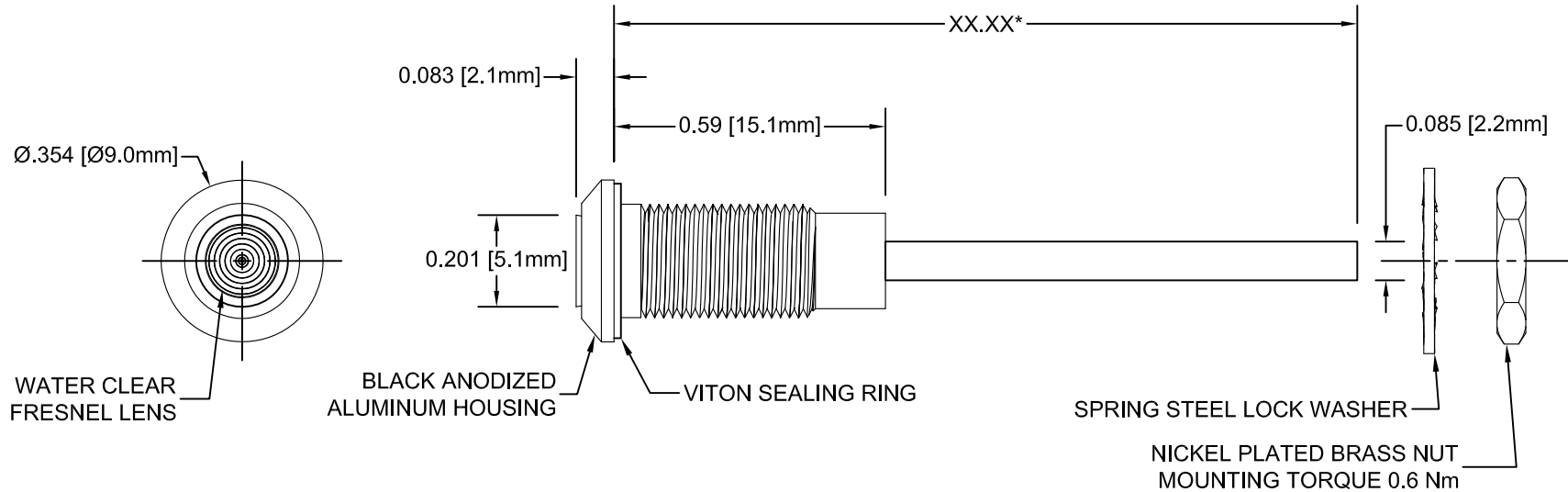

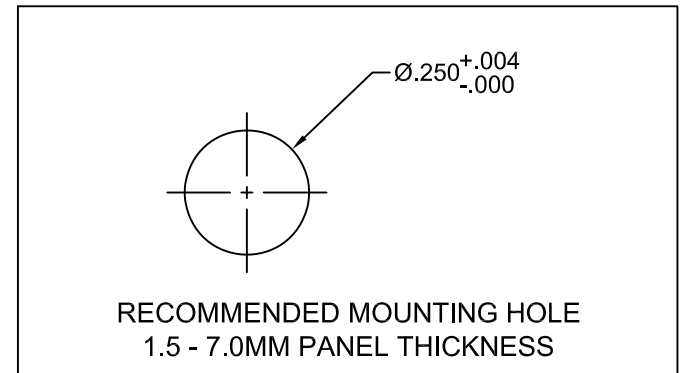

*Length "XX.XX"	Tolerance
2.50" ~ 16.00"	±0.050"
16.25" ~ 40.00"	±0.15"
40.25" ~ 80.00"	±0.30"
80.25" ~ 500.0"	±0.5%

EXAMPLE:
PM3-A1522-6.50
 Series Fiber Length in 0.25" Increments



NOTES:

1. SEALED TO IP67 RATING
2. ROHS COMPLIANT
3. MOUNTING HARDWARE SHIPPED NON-ASSEMBLED
4. INSERT VITON RING ON PANEL MOUNT PRIOR TO PANEL INSERTION

STANDARD TOLERANCE (UNLESS OTHERWISE SPECIFIED)		 4 THOMAS, IRVINE, CA. 92618 TEL: (949) 951-8808 FAX: (949) 951-3974				
DECIMALS	ANGULAR					
.X ±.1	X° ± 1°		TITLE: IP67 RATED METAL PANEL MOUNT FLP INDICATOR			
.XX ±.02			DESIGNED: Ty Yin	DATE: 03/15/12	PART NO: PM3-A1522-XX.XX	REVISION: B
.XXX ±.010			CHECKED: B. Oilver	DATE: 03/15/12	CAGE CODE : 32559	SHEET # 1 OF 1
				CAD GENERATED DOCUMENT, DO NOT MEASURE DRAWING.		