

REV.	DESCRIPTION	DATE	APPROVED
B	Engineering Release	03/15/12	T. Y.

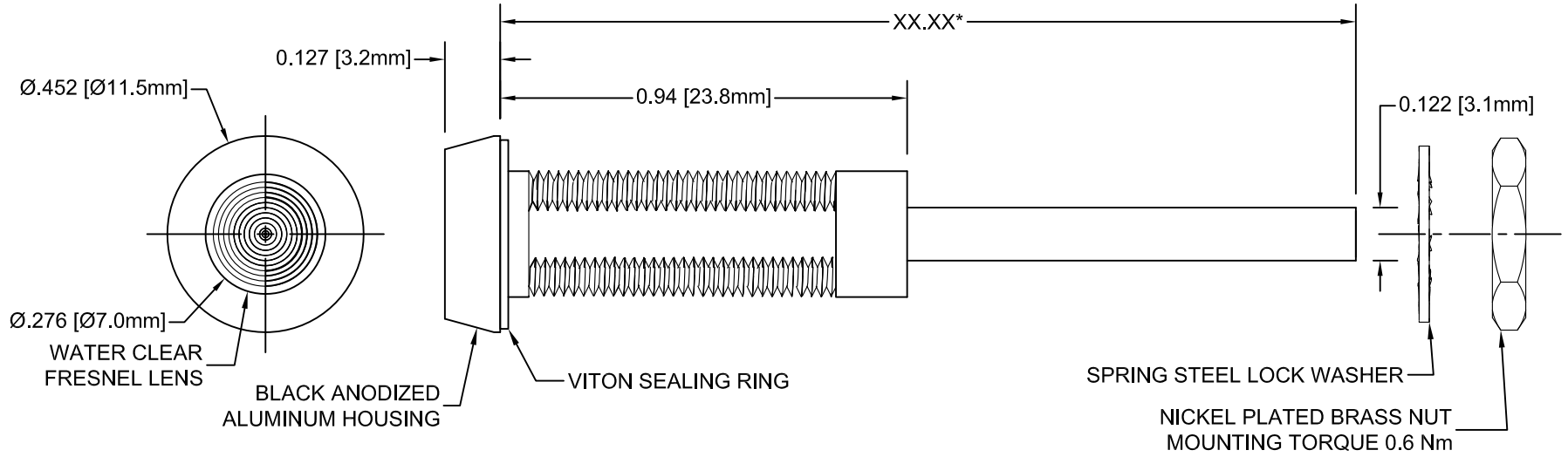

*Length "XX.XX"	Tolerance
2.50" ~ 16.00"	±0.050"
16.25" ~ 40.00"	±0.15"
40.25" ~ 80.00"	±0.30"
80.25" ~ 500.0"	±0.5%

EXAMPLE:
PM5-A2031-6.50
 Series Fiber Length in 0.25" Increments

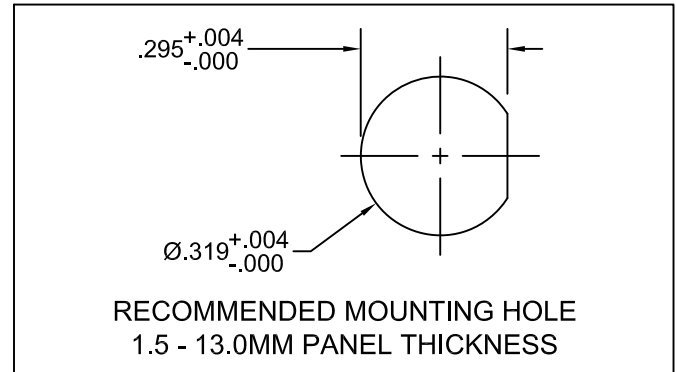

- NOTES:**
1. SEALED TO IP67 RATING
 2. ROHS COMPLIANT
 3. MOUNTING HARDWARE SHIPPED NON-ASSEMBLED
 4. INSERT VITON RING ON PANEL MOUNT PRIOR TO PANEL INSERTION

STANDARD TOLERANCE (UNLESS OTHERWISE SPECIFIED)		BIVAR [®] 4 THOMAS, IRVINE, CA. 92618 TEL: (949) 951-8808 FAX: (949) 951-3974
DECIMALS	ANGULAR	
.X ±.1	X° ± 1°	TITLE: IP67 RATED METAL PANEL MOUNT FLP INDICATORS REVISION: B
.XX ±.02		
.XXX ±.010		
DESIGNED: Ty Yin	DATE: 03/15/12	PART NO: PM5-A2031-XX.XX
CHECKED: B. Oliver	DATE: 03/15/12	CAGE CODE : 32559 SHEET # 1 OF 1
CAD GENERATED DOCUMENT. DO NOT MEASURE DRAWING.		