

# *ASSP for Power Management Applications*

BIPOLAR

## **Switching Regulator Controller** (Switchable between push-pull and single-end functions)

# **MB3759**

### ■ DESCRIPTION

The MB3759 is a control IC for constant-frequency pulse width modulated switching regulators. The IC contains most of the functions required for switching regulator control circuits. This reduces both the component count and assembly work.

### ■ FEATURES

- Drives a 200 mA load
- Can be set to push-pull or single-end operation
- Prevents double pulses
- Adjustable dead-time
- Error amplifier has wide common phase input range
- Built in a circuit to prevent misoperation due to low power supply voltage.
- Built in an internal 5 V reference voltage with superior voltage reduction characteristics
- One type of package (SOP-16pin : 1 type)

### ■ Application

- Power supply module
- Industrial Equipment
- AC/DC Converter      etc.

## ■ PIN ASSIGNMENT

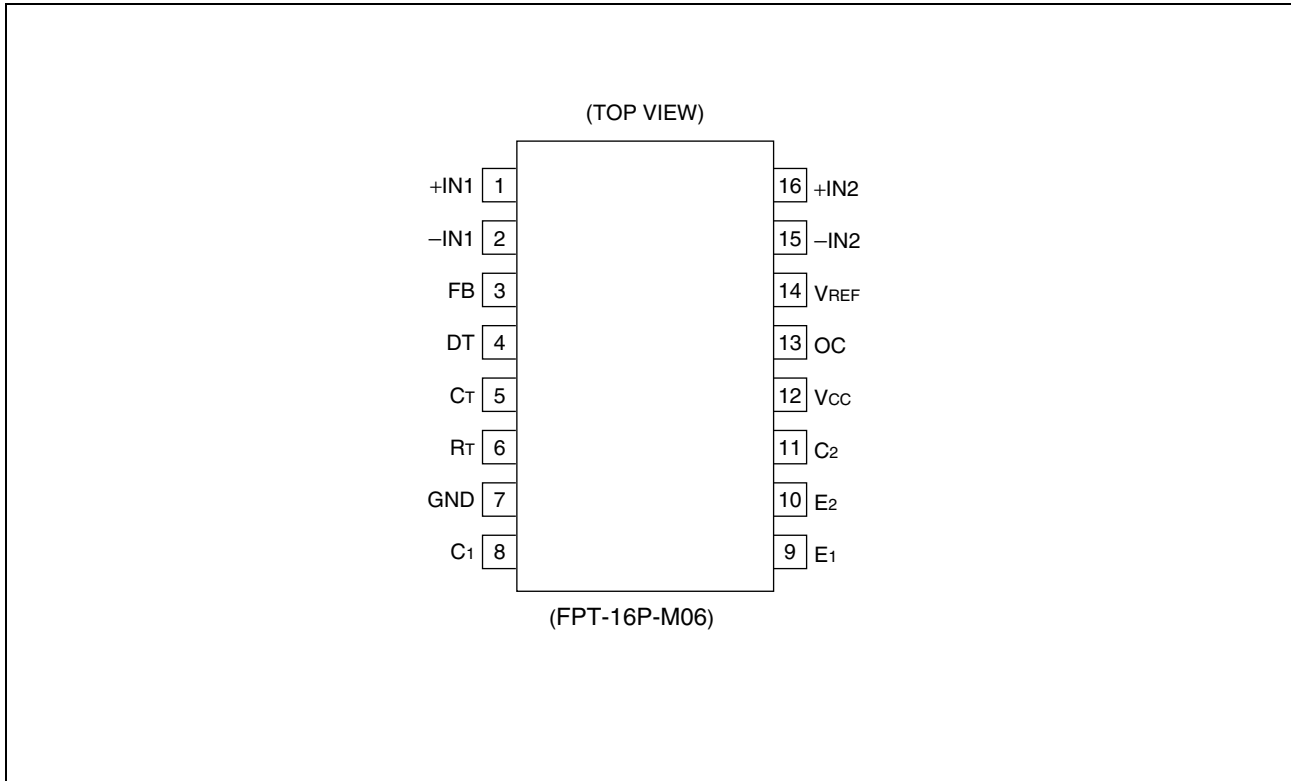

## ■ BLOCK DIAGRAM

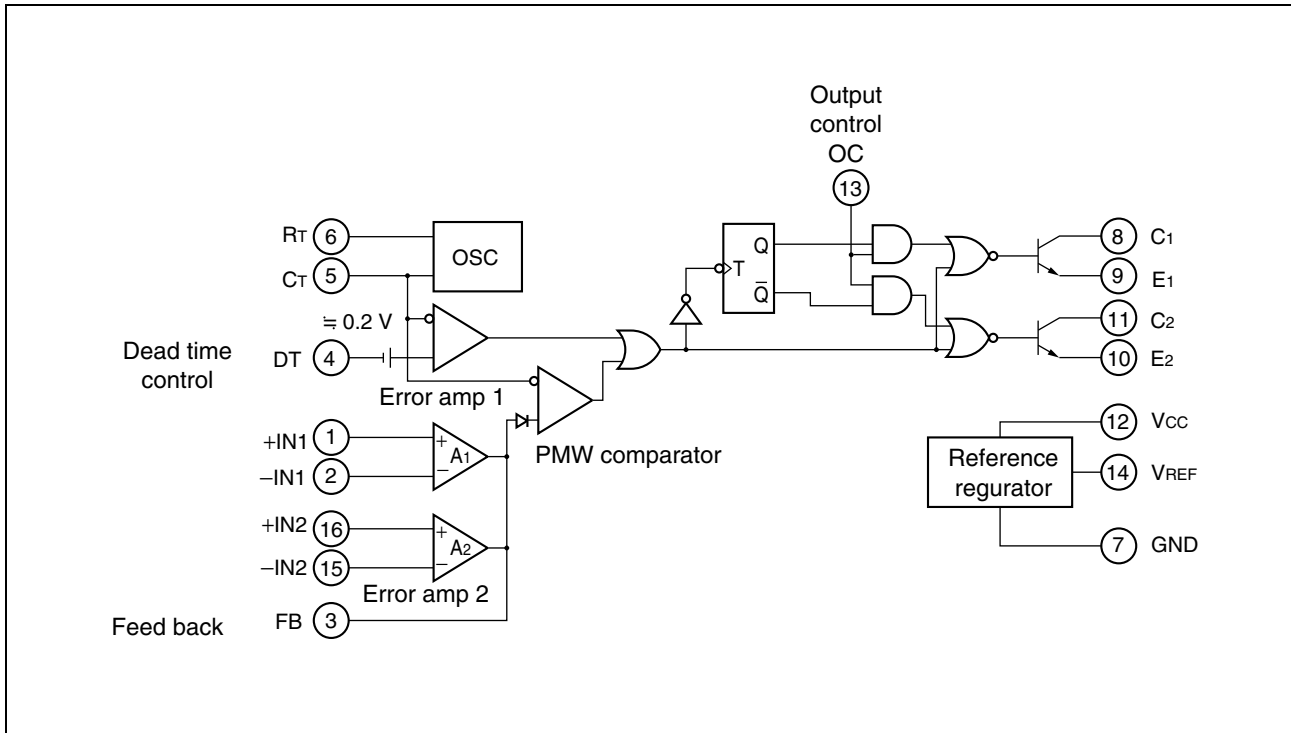

## ■ ABSOLUTE MAXIMUM RATINGS

Parameter	Symbol	Condition	Rating		Unit
			Min	Max	
Power supply voltage	$V_{CC}$	—	—	41	V
Collector output voltage	$V_{CE}$	—	—	41	V
Collector output current	$I_{CE}$	—	—	250	mA
Amplifier input voltage	$V_I$	—	—	$V_{CC} + 0.3$	V
Power dissipation	SOP *	$P_D$	$T_a \leq +25\text{ °C}$	620	mW
Operating ambient temperature	$T_a$	—	—30	+85	°C
Storage temperature	$T_{stg}$	—	—55	+125	°C

\*: When mounted on a 4 cm square double-sided epoxy circuit board (1.5 mm thickness)  
 The ceramic circuit board is 3 cm x 4 cm (0.5 mm thickness)

WARNING: Semiconductor devices can be permanently damaged by application of stress (voltage, current, temperature, etc.) in excess of absolute maximum ratings. Do not exceed these ratings.

## ■ RECOMMENDED OPERATING CONDITIONS

Parameter	Symbol	Value			Unit
		Min	Typ	Max	
Power supply voltage	$V_{CC}$	7	15	32	V
Collector output voltage	$V_{CE}$	—	—	40	V
Collector output current	$I_{CE}$	5	—	200	mA
Amplifier input voltage	$V_{IN}$	-0.3	0 to $V_R$	$V_{CC} - 2$	V
FB sink current	$I_{SINK}$	—	—	0.3	mA
FB source current	$I_{SOURCE}$	—	—	2	mA
Reference section output current	$I_{REF}$	—	5	10	mA
Timing resistor	$R_T$	1.8	30	500	k $\Omega$
Timing capacitor	$C_T$	470	1000	$10^6$	pF
Oscillator frequency	$f_{osc}$	1	40	300	kHz
Operating ambient temperature	$T_a$	-30	+25	+85	°C

Note: Values are for standard derating conditions. Give consideration to the ambient temperature and power consumption if using a high supply voltage.

WARNING: The recommended operating conditions are required in order to ensure the normal operation of the semiconductor device. All of the device's electrical characteristics are warranted when the device is operated within these ranges.

Always use semiconductor devices within their recommended operating condition ranges. Operation outside these ranges may adversely affect reliability and could result in device failure. No warranty is made with respect to uses, operating conditions, or combinations not represented on the data sheet. Users considering application outside the listed conditions are advised to contact their representatives beforehand.

## ■ ELECTRICAL CHARACTERISTICS

( $V_{CC} = 15\text{ V}$ ,  $T_a = +25\text{ }^\circ\text{C}$ )

Parameter		Symbol	Condition	Value			Unit	
				Min	Typ	Max		
Reference section	Output voltage	$V_{REF}$	$I_o = 1\text{ mA}$	4.75	5.0	5.25	V	
	Input regulation	$\Delta V_{R(IN)}$	$7\text{ V} \leq V_{CC} \leq 40\text{ V}$ , $T_a = +25\text{ }^\circ\text{C}$	—	2	25	mV	
	Load regulation	$\Delta V_{R(LD)}$	$1\text{ mA} \leq I_o \leq 10\text{ mA}$ , $T_a = +25\text{ }^\circ\text{C}$	—	-1	-15	mV	
	Temperature stability	$\Delta V_R/\Delta T$	$-20\text{ }^\circ\text{C} \leq T_a \leq +85\text{ }^\circ\text{C}$	—	$\pm 200$	$\pm 750$	$\mu\text{V}/^\circ\text{C}$	
	Short circuit output current	$I_{SC}$	—	15	40	—	mA	
	Reference lockout voltage	—	—	—	4.3	—	V	
	Reference hysteresis voltage	—	—	—	0.3	—	V	
Oscillator section	Oscillator frequency	$f_{osc}$	$R_T = 30\text{ k}\Omega$ , $C_T = 1000\text{ pF}$	36	40	44	kHz	
	Standard deviation of frequency	—	$R_T = 30\text{ k}\Omega$ , $C_T = 1000\text{ pF}$	—	$\pm 3$	—	%	
	Frequency change with voltage	—	$7\text{ V} \leq V_{CC} \leq 40\text{ V}$ , $T_a = +25\text{ }^\circ\text{C}$	—	$\pm 0.1$	—	%	
	Frequency change with temperature	$\Delta f_{osc}/\Delta T$	$-20\text{ }^\circ\text{C} \leq T_a \leq +85\text{ }^\circ\text{C}$	—	$\pm 0.01$	—	$\%/^\circ\text{C}$	
Dead-time control section	Input bias current	$I_D$	$0 \leq V_I \leq 5.25\text{ V}$	—	-2	-10	$\mu\text{A}$	
	Maximum duty cycle (Each output)	—	$V_I = 0$	40	45	—	%	
	Input threshold voltage	0% duty cycle	$V_{DO}$	—	—	3.0	3.3	V
		Max duty cycle	$V_{DM}$	—	0	—	—	V

(Continued)

(Continued)

( $V_{CC} = 15\text{ V}$ ,  $T_a = +25\text{ }^\circ\text{C}$ )

Parameter		Symbol	Condition	Value			Unit	
				Min	Typ	Max		
Error amplifier section	Input offset voltage		$V_{IO}$	$V_{O(\text{pin}3)} = 2.5\text{ V}$	—	$\pm 2$	$\pm 10$	mV
	Input offset current		$I_{IO}$	$V_{O(\text{pin}3)} = 2.5\text{ V}$	—	$\pm 25$	$\pm 250$	nA
	Input bias current		$I_I$	$V_{O(\text{pin}3)} = 2.5\text{ V}$	—	-0.2	-1.0	$\mu\text{A}$
	Common-mode input voltage		$V_{CM}$	$7\text{ V} \leq V_{CC} \leq 40\text{ V}$	-0.3	—	$V_{CC} - 2$	V
	Open-loop voltage amplification		$A_V$	$0.5\text{ V} \leq V_O \leq 3.5\text{ V}$	70	95	—	dB
	Unity-gain bandwidth		BW	$A_V = 1$	—	800	—	kHz
	Common-mode rejection ratio		CMR	$V_{CC} = 40\text{ V}$	65	80	—	dB
	Output sink current (pin 3)	ISINK	$I_{SINK}$	$-5\text{ V} \leq V_{ID} \leq -15\text{ mV}$ , $V_O = 0.7\text{ V}$	0.3	0.7	—	mA
ISOURCE		$I_{SOURCE}$	$15\text{ mV} \leq V_{ID} \leq 5\text{ V}$ , $V_O = 3.5\text{ V}$	-2	-10	—	mA	
Output section	Collector leakage current		$I_{CO}$	$V_{CE} = 40\text{ V}$ , $V_{CC} = 40\text{ V}$	—	—	100	$\mu\text{A}$
	Emitter leakage current		$I_{EO}$	$V_{CC} = V_C = 40\text{ V}$ , $V_E = 0$	—	—	-100	$\mu\text{A}$
	Collector emitter saturation voltage	Emitter grounded	$V_{SAT(C)}$	$V_E = 0$ , $I_C = 200\text{ mA}$	—	1.1	1.3	V
		Emitter follower	$V_{SAT(E)}$	$V_C = 15\text{ V}$ , $I_E = -200\text{ mA}$	—	1.5	2.5	V
	Output control input current		$I_{OPC}$	$V_I = V_{REF}$	—	1.3	3.5	mA
PWM comparator section	Input threshold voltage		$V_{TH}$	0% Duty	—	4	4.5	V
	Input sink current (pin 3)		$I_{SINK}$	$V_{O(\text{pin}3)} = 0.7\text{ V}$	0.3	0.7	—	mA
Power supply current			$I_{CC}$	$V(\text{pin}4) = 2\text{ V}$ , Refer to "■ TEST CIRCUIT"	—	8	—	mA
Standby current			$I_{CCQ}$	$V(\text{pin}6) = V_{REF}$ , I/O open	—	7	12	mA
Switching characteristics	Rise time	Emitter grounded	$t_R$	$R_L = 68\ \Omega$	—	100	200	ns
	Fall time		$t_F$	$R_L = 68\ \Omega$	—	25	100	ns
	Rise time	Emitter follower	$t_R$	$R_L = 68\ \Omega$	—	100	200	ns
	Fall time		$t_F$	$R_L = 68\ \Omega$	—	40	100	ns

## ■ TEST CIRCUIT

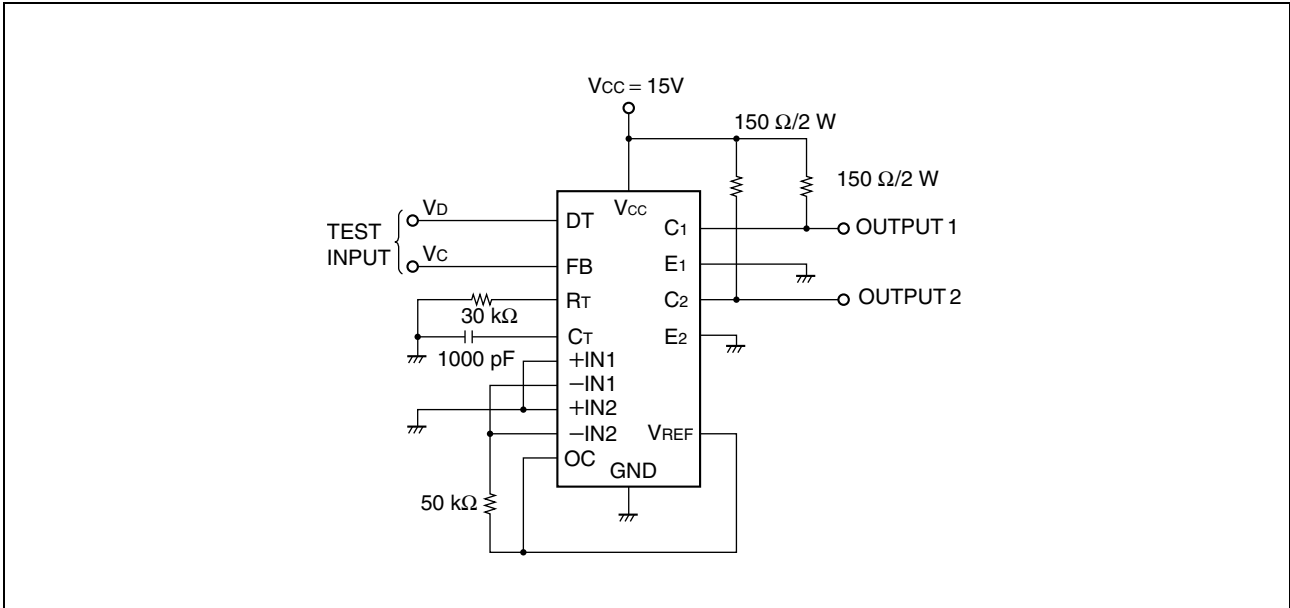

## ■ OPERATING TIMING

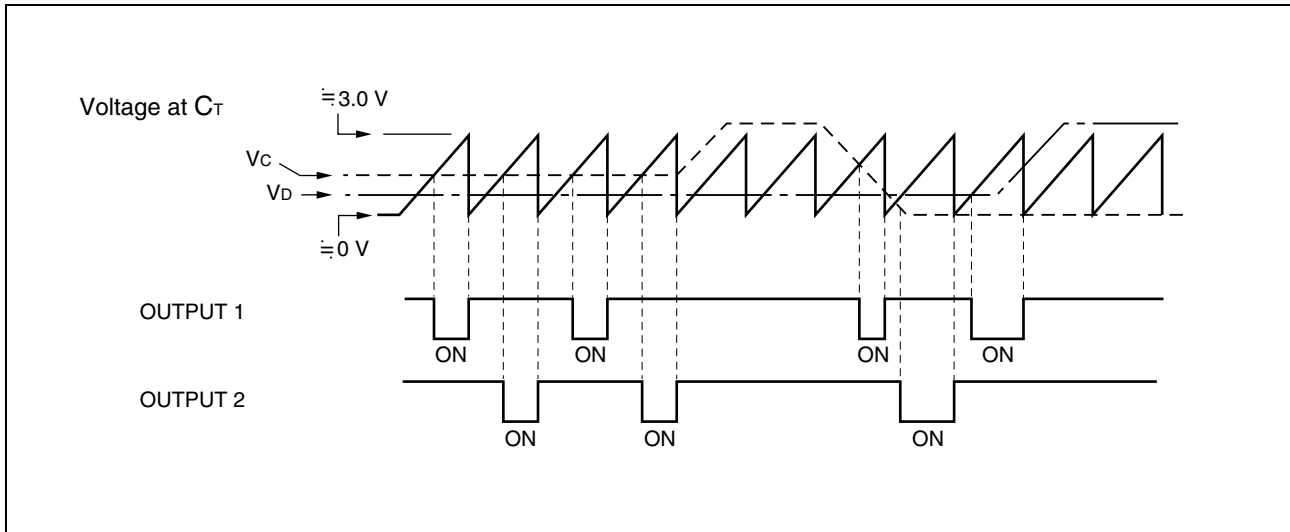

## ■ OSCILLATION FREQUENCY

$$f_{OSC} \approx \frac{1.2}{R_T \times C_T}$$

$R_T$  : k $\Omega$   
 $C_T$  :  $\mu$ F  
 $f_{osc}$  : kHz

## ■ OUTPUT LOGIC TABLE

Input (Output Control)	Output State
GND	Single-ended or parallel output
$V_{REF}$	Push-pull

## TYPICAL CHARACTERISTICS

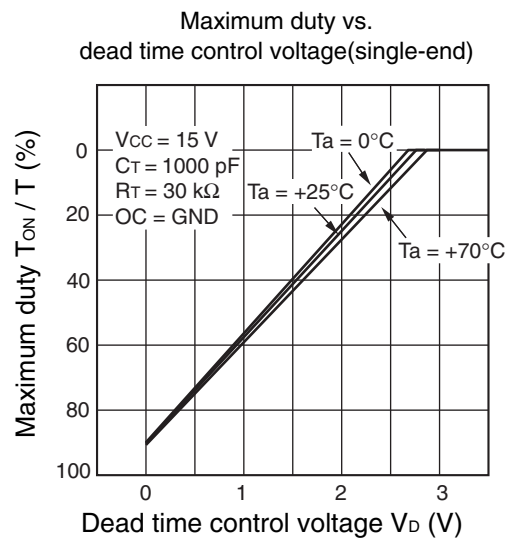
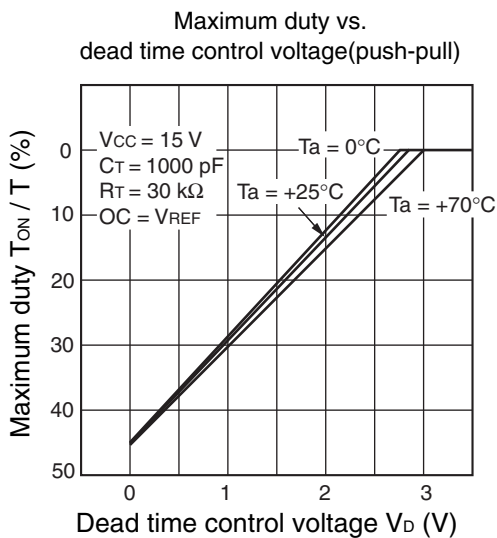
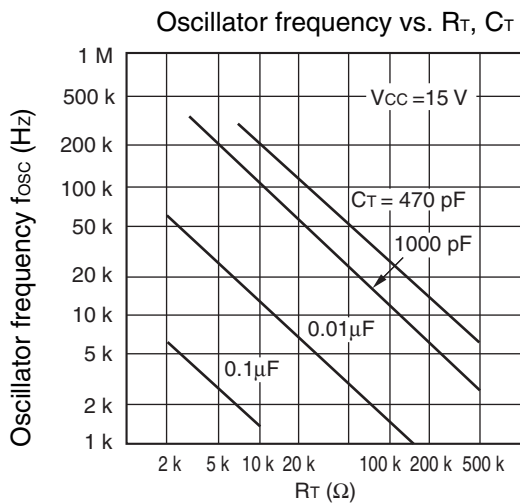
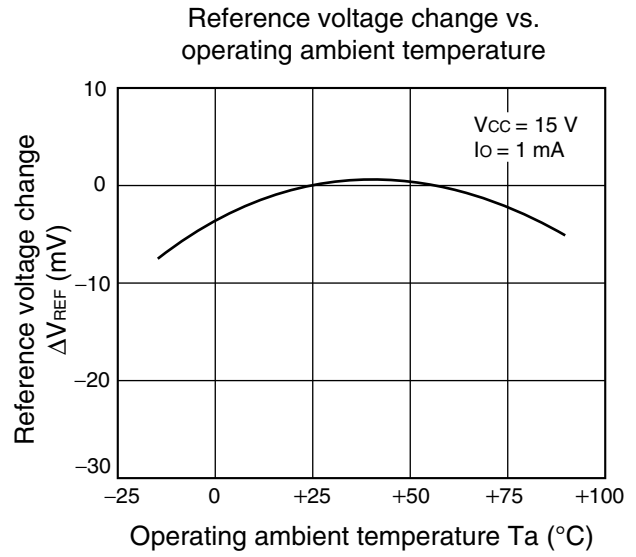
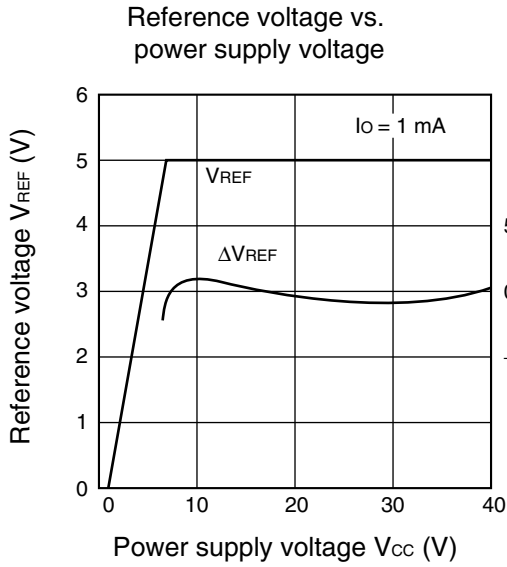

(Continued)



Open loop voltage amplification vs. frequency

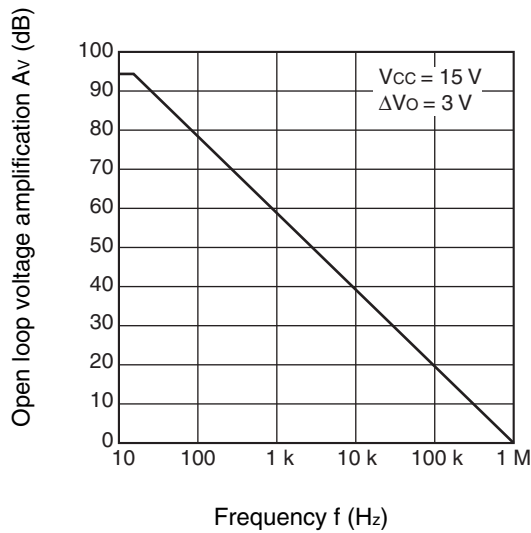

Output voltage vs. output current (feed back terminal)

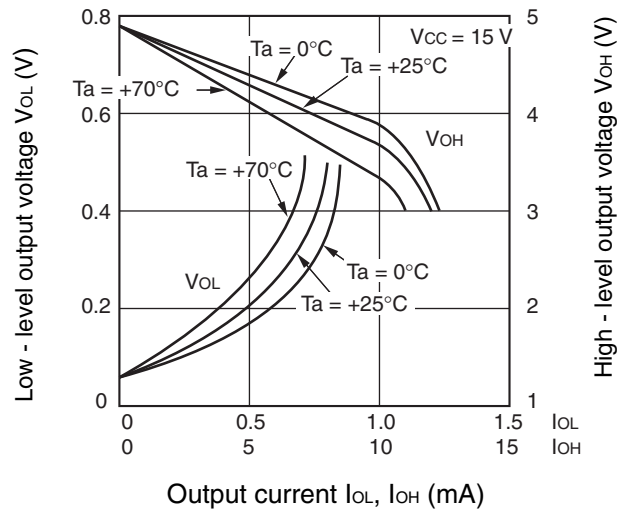

Collector saturation voltage vs. collector output current

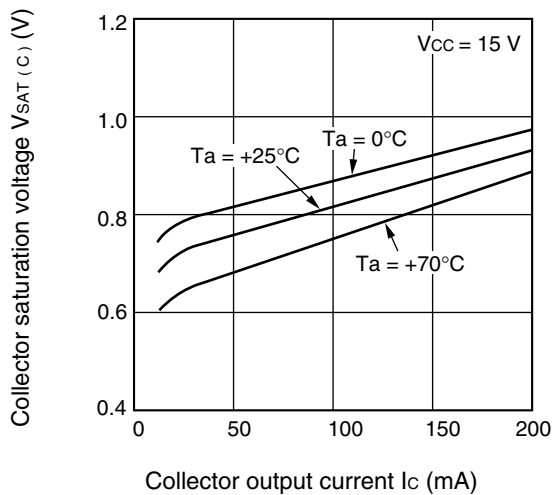

Emitter saturation voltage vs. emitter output current

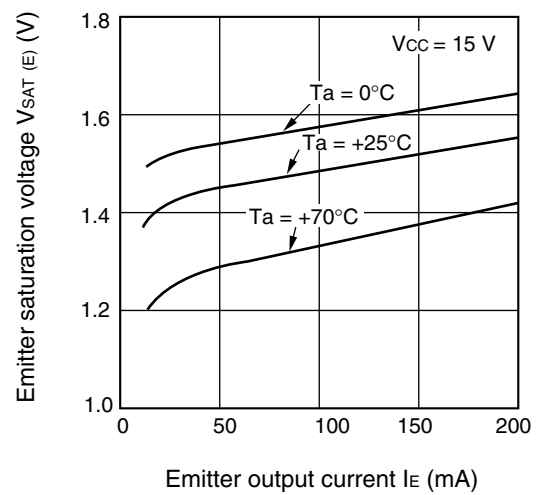

(Continued)

(Continued)

Output voltage vs. reference voltage

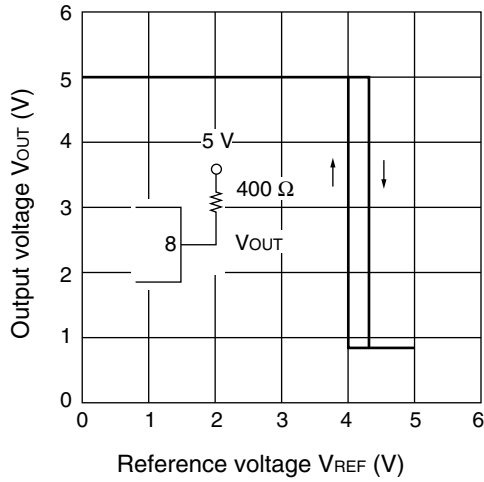

Power supply current vs. power supply voltage

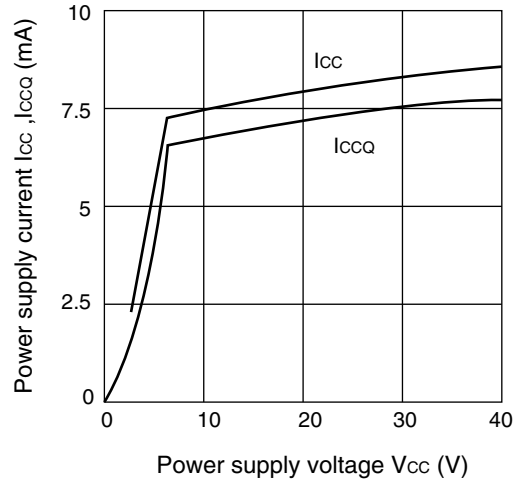

Power dissipation vs. power supply voltage

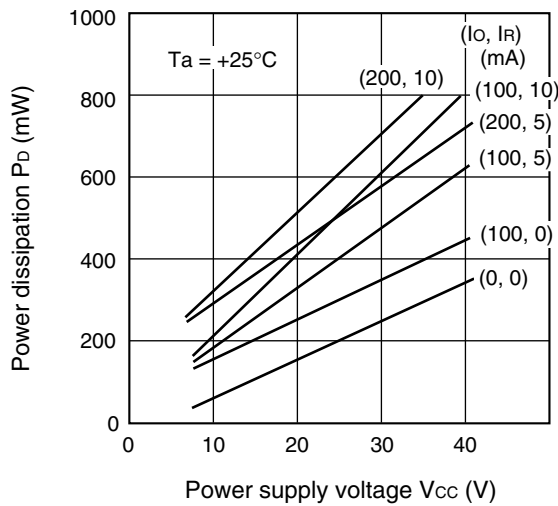

Power dissipation vs. Operating ambient temperature

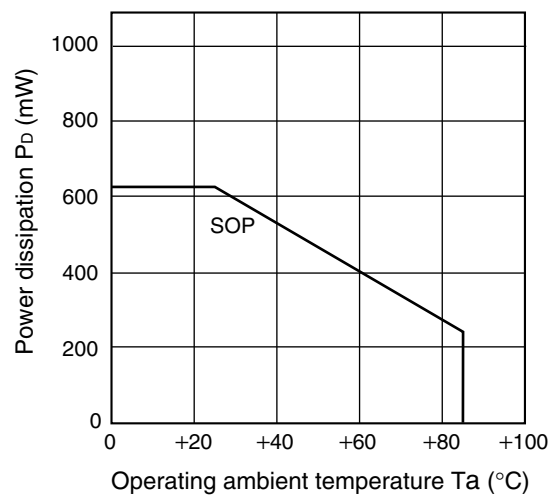

## ■ BASIC OPERATION

Switching regulators can achieve a high level of efficiency. This section describes the basic principles of operation using a chopper regulator as an example.

As shown in the diagram, diode D provides a current path for the current through inductance L when Q is off. Transistor Q performs switching and is operated at a frequency that provides a stable output. As the switching element is saturated when Q is on and cutoff when Q is off, the losses in the switching element are much less than for a series regulator in which the pass transistor is always in the active state.

While Q is conducting, the input voltage  $V_{IN}$  is supplied to the LC circuit and when Q is off, the energy stored in L is supplied to the load via diode D. The LC circuit smooths the input to supply the output voltage.

The output voltage  $V_O$  is given by the following equation.

$$V_O = \frac{T_{on}}{T_{on} + T_{off}} V_{IN} = \frac{T_{on}}{T} V_{IN}$$

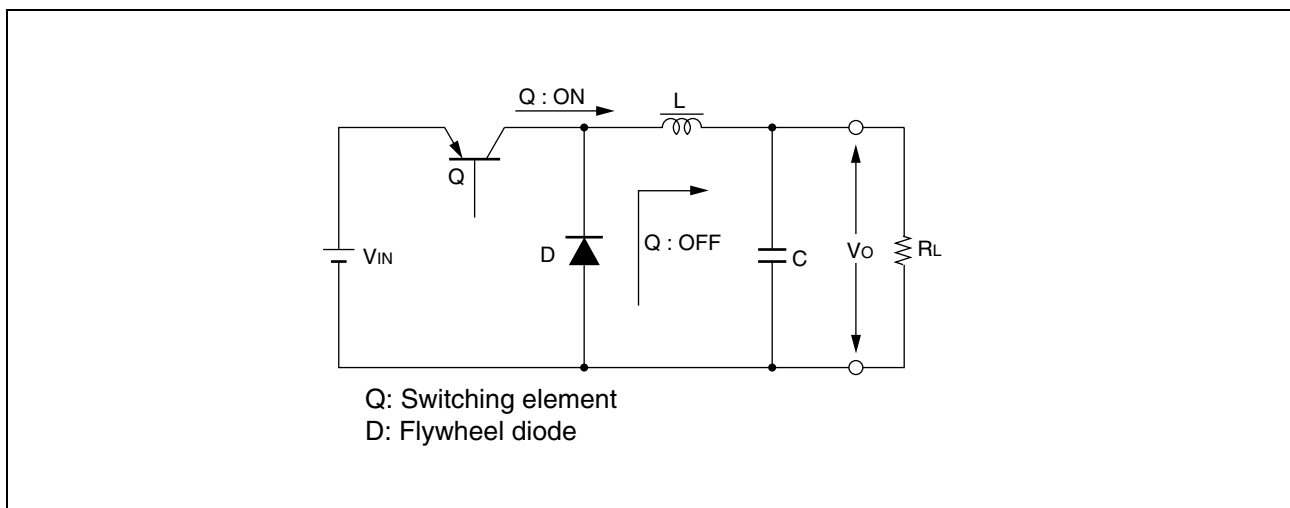

As indicated by the equation, variation in the input voltage is compensated for by controlling the duty cycle ( $T_{on}/T$ ). If  $V_{IN}$  drops, the control circuit operates to increase the duty cycle so as to keep the output voltage constant.

The current through L flows from the input to the output when Q is on and through D when Q is off. Accordingly, the average input current  $I_{IN}$  is the product of the output current and the duty cycle for Q.

$$I_{IN} = \frac{T_{on}}{T} I_o$$

The theoretical conversion efficiency if the switching loss in Q and loss in D are ignored is as follows.

$$\begin{aligned} \eta &= \frac{P_o}{P_{IN}} \times 100 (\%) \\ &= \frac{V_o \times I_o}{V_{IN} \times I_{IN}} \times 100 \\ &= \frac{V_{IN} \times I_o \times T_{on} / T}{V_{IN} \times I_o \times T_{on} / T} \times 100 \\ &= 100 (\%) \end{aligned}$$

The theoretical conversion efficiency is 100%. In practice, losses occur in the switching element and elsewhere, and design decisions to minimize these losses include making the switching frequency as low as practical and setting an optimum ratio of input to output voltage.

## ■ SWITCHING ELEMENT

### 1. Selection of the Switching Transistor

It can be said that the success or otherwise of a switching regulator is determined by the choice of switching transistor. Typically, the following parameters are considered in selecting a transistor.

- Withstand voltage
- Current
- Power
- Speed

For the withstand voltage, current, and power, it is necessary to determine that the area of safe operation (ASO) of the intended transistor covers the intended range for these parameters.

The speed (switching speed: rise time  $t_r$ , storage time  $t_{stg}$ , and fall time  $t_f$ ) is related to the efficiency and also influences the power.

The figures show the transistor load curve and  $V_{CE} - I_C$  waveforms for chopper and inverter-type regulators. The chopper regulator is a relatively easy circuit to deal with as the diode clamps the collector. A peak can be seen immediately after turn-on. However, this is due to the diode and is explained later.

In an inverter regulator, the diodes on the secondary side act as a clamp. Viewed from the primary side, however, a leakage inductance is present. This results in an inductive spike which must be taken account of as it is added to double the  $V_{IN}$  voltage.

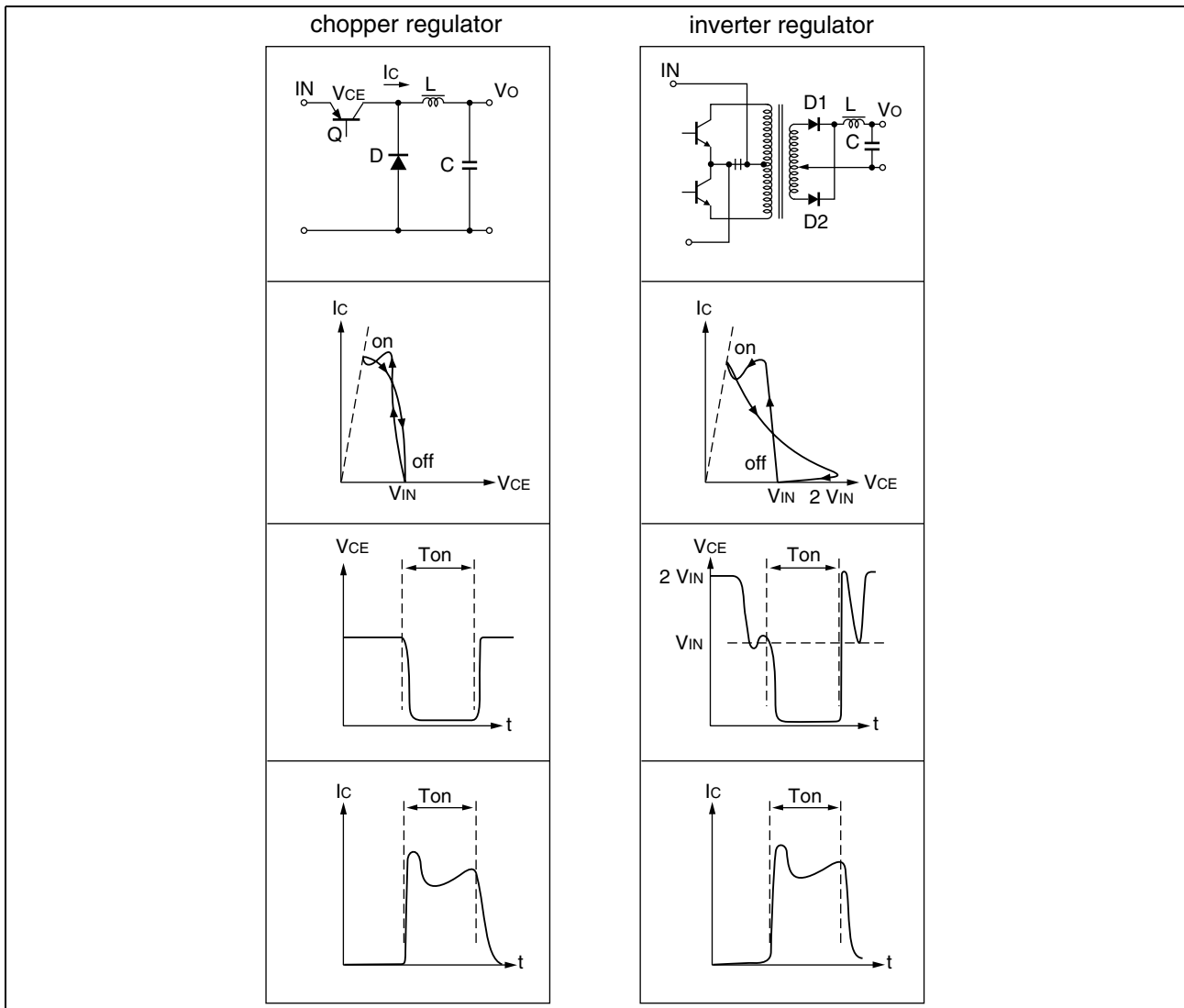

The figure below shows an example of the ASO characteristics for a forward-biased power transistor (2SC3058A) suitable for switching.

Check that the ASO characteristics for the transistor you intend to use fully covers the load curve. Next, check whether the following conditions are satisfied. If so, the transistor can be expected to perform the switching operation safely.

- The intended ON time does not exceed the ON-time specified for the ASO characteristic.
- The OFF-time ASO characteristic satisfies the intended operation conditions.
- Derating for the junction temperature has been taken into account.

For a switching transistor, the junction temperature is closely related to the switching speed. This is because the switching speed becomes slower as the temperature increases and this affects the switching losses.

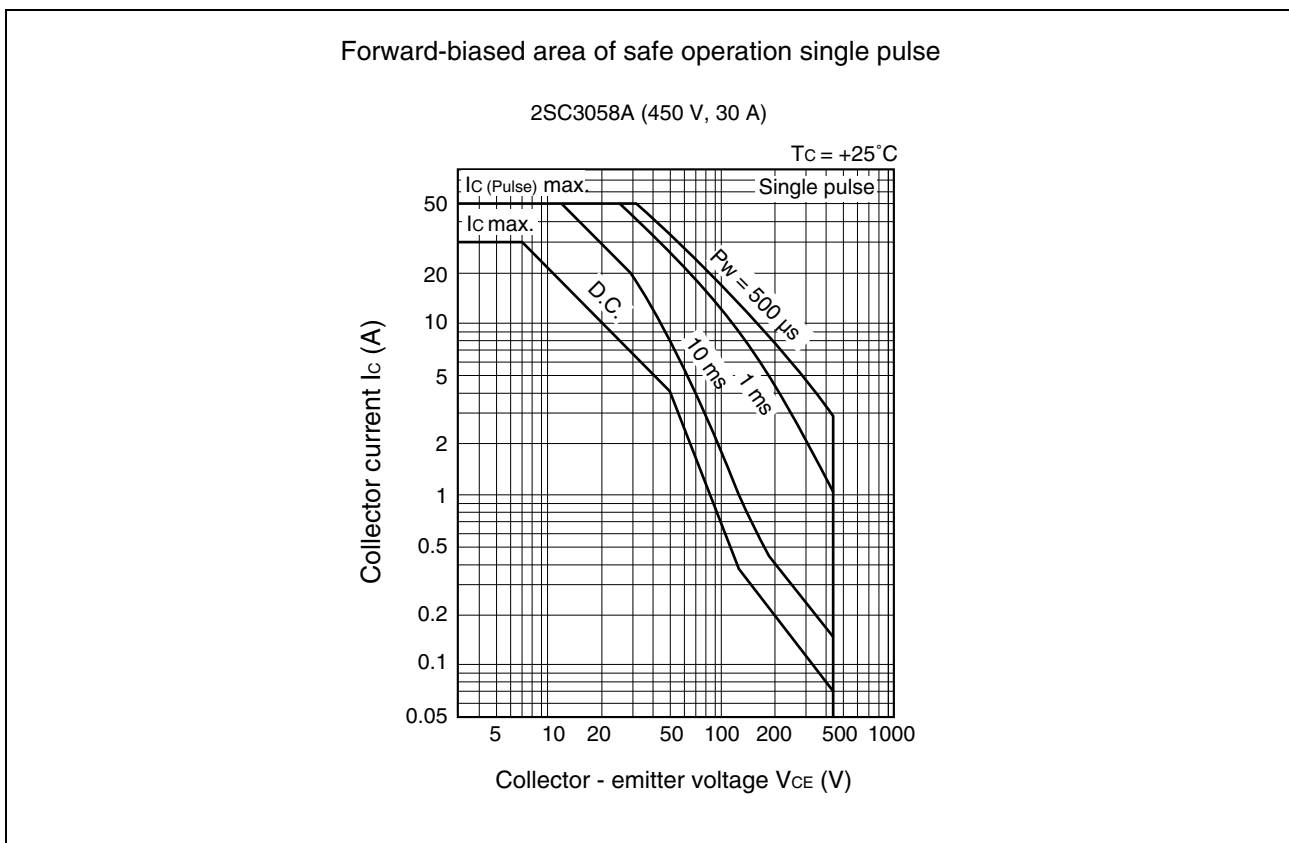

## 2. Selecting the Diode

Consideration must be given to the switching speed when selecting the diode. For chopper regulators in particular, the diode affects the efficiency and noise characteristics and has a big influence on the performance of the switching regulator.

If the reverse recovery time of the diode is slower than the turn-on time of the transistor, an in-rush current of more than twice the load current occurs resulting in noise (spikes) and reduced efficiency.

As a rule for diode selection, use a diode with a reverse recovery time  $t_{rr}$  that is sufficiently faster than the transistor  $t_r$ .

## ■ APPLICATION IN PRACTICAL CIRCUITS

### 1. Error Amplifier Gain Adjustment

Take care that the bias current does not become large when connecting an external circuit to the FB pin (pin 3) for adjusting the amplifier gain. As the FB pin (pin 3) is biased to the low level by a sink current, the duty cycle of the output signal will be affected if the current from the external circuit is greater than the amplifier can sink.

The figure below shows a suitable circuit for adjusting the gain.

It is very important that you avoid having a capacitive load connected to the output stage as this will affect the response time.

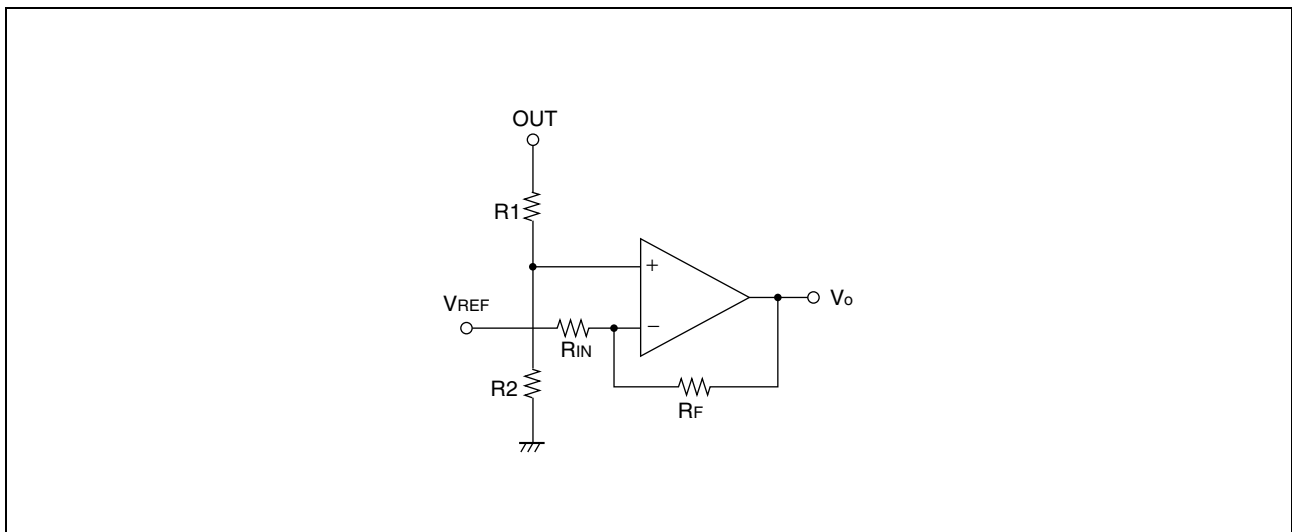

### 2. Synchronized Oscillator Operation

The oscillator can be halted by connecting the  $C_T$  pin (pin 5) to the GND pin (pin 7). If supplying the signal externally, halt the internal oscillator and input to the  $C_T$  pin (pin 5).

Using this method, multiple ICs can be used together in synchronized operation. For synchronized operation, set one IC as the master and connect the other ICs as shown in the diagram.

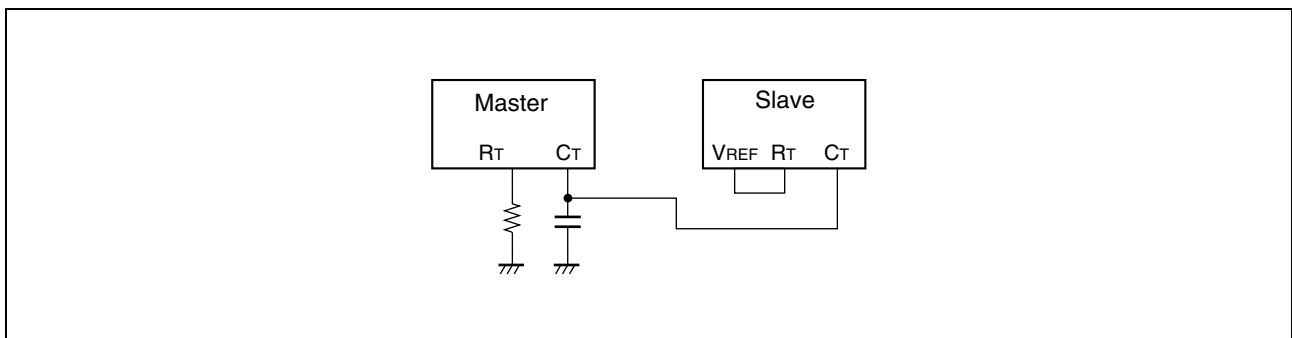

### 3. Setting The Idle Period

When the voltage at the FB pin may go lower than the triangular wave voltage due to load fluctuation, etc. In this case, the output transistor will be almost in full-on state. This can be prevented by setting the maximum duty for the output transistor. This is done by setting the DT pin (pin 4) voltage using resistance division of the  $V_{REF}$  voltage as illustrated below.

When the DT pin voltage is lower than the triangular waveform voltage, the output transistor is turned on. If the triangular waveform amplitude specified by the maximum duty calculation formula is 3.0V, and the lower voltage limit of the triangular waveform is 0.0 V, DT offset = 0.2 V, the formula would be as follows:

- push pull

$$\text{Maximum Duty(\%)} = \frac{3.0V - (V_{dt} + 0.2V)}{3.0V} \times 50 = \frac{2.8V - V_{dt}}{3.0V} \times 50$$

- single-end

$$\text{Maximum Duty(\%)} = \frac{3.0V - (V_{dt} + 0.2V)}{3.0V} \times 100 = \frac{2.8V - V_{dt}}{3.0V} \times 100$$

Also, if no maximum duty setting is required, it is necessary to set the voltage to  $V_{dt} = 0.0$  V.

- Setting the idle period at DT

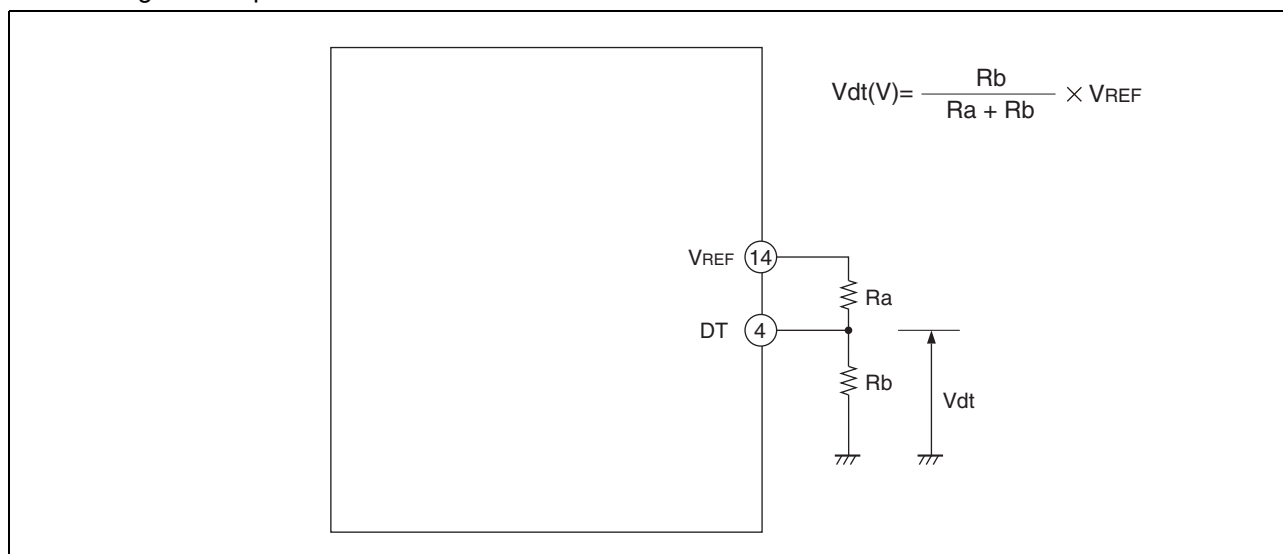

See “Maximum duty vs. dead time control voltage” in “■ TYPICAL CHARACTERISTICS” for details.

## 4. Soft Start

A soft start function can be incorporated by using the dead-time control element (DT) pin (pin 4).

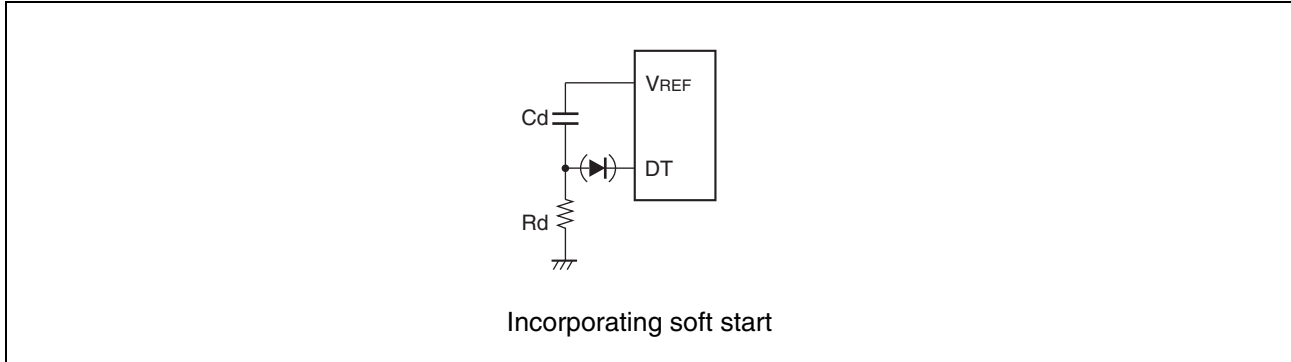

When the power is turned on, Cd is not yet charged and the DT input is pulled to the VREF pin (pin 14) causing the output transistor to turn off. Next, the input voltage to the DT pin (pin 4) drops in accordance with the Cd, Rd constant causing the output pulse width to increase steadily, providing stable control circuit operation. If you wish to use both dead-time and softstart, combine these in an OR configuration.

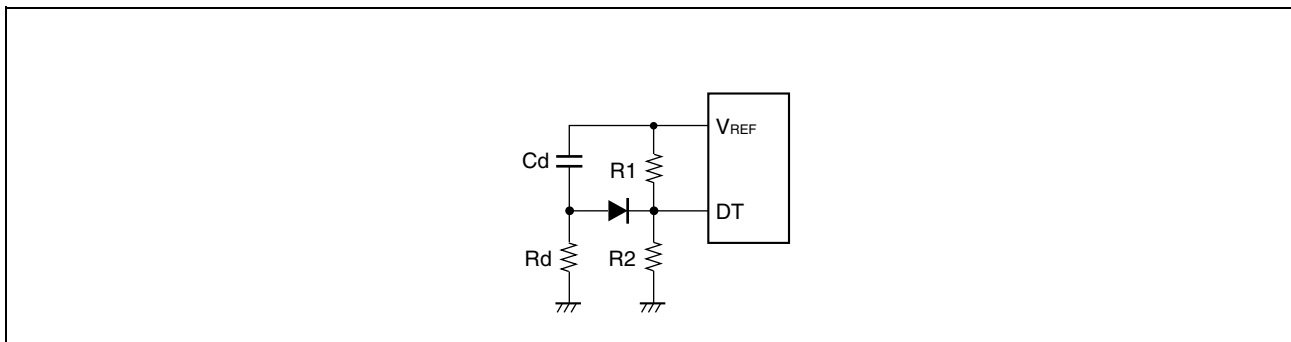

## 5. Output Current Limiting (Fallback system using a detection resistor inserted on the output side)

### (1) Typical example

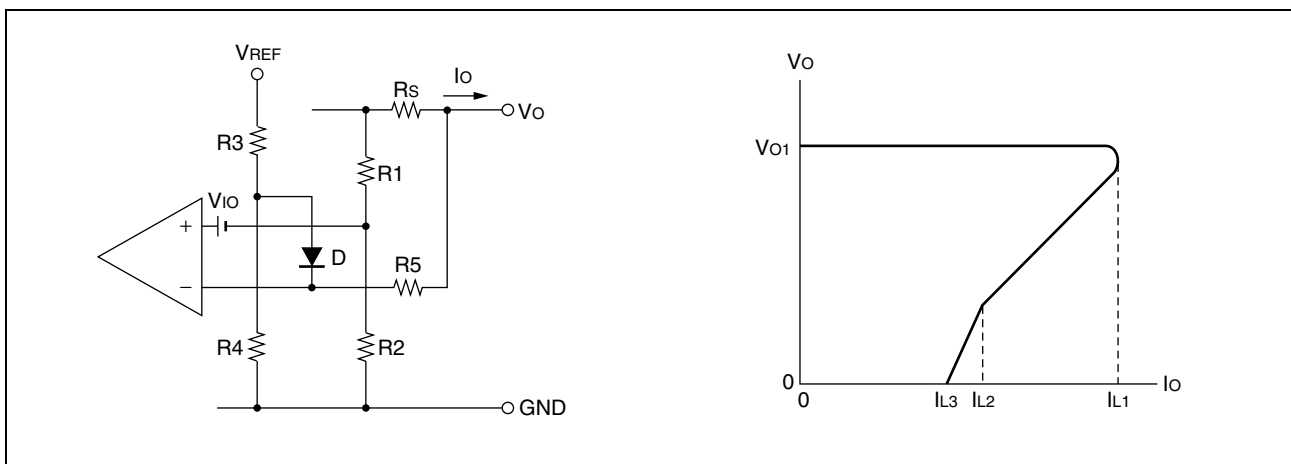



- Initial limit current  $I_{L1}$

The condition for  $V_o$  is:  $V_o > \frac{R_4}{R_3 + R_4} V_{REF}$

As the diode is reverse biased,

$$R_s I_{L1} = \frac{R_1}{R_1 + R_2} V_o - V_{IO}$$

$$\therefore I_{L1} = \frac{R_1}{R_1 + R_2} \frac{V_o}{R_s} - \frac{V_{IO}}{R_s} \quad \text{Eq. (1) (where } R_2 \gg R_1 \text{)}$$

$V_{IO}$  is the input offset voltage to the op-amp ( $-10 \text{ mV} \leq V_{IO} \leq +10 \text{ mV}$ ) and this causes the variation in  $I_L$ . Accordingly, if for example the variation in  $I_L$  is to be limited to  $\pm 10\%$ , using equation (1) and only considering the variation in the offset voltage gives the following:

$$I_o = \frac{1}{R_s} \frac{R_1}{R_1 + R_2} (V_o + V_{EE}) - \frac{V_{IO}}{R_s} \quad (R_2 \gg R_1)$$

This indicates a setting of 100 mV or more is required.

- Polarity change point  $I_{L2}$

As this is the point where the diode becomes forward biased, it can be calculated by substituting  $[R_4/(R_3+R_4) V_{REF} - V_D]$  for  $V_o$  in equation (where  $V_D$  is the forward voltage of the diode).

$$I_{L2} = \frac{R_1}{R_1 + R_2} \frac{R_4 / (R_3 + R_4) \cdot V_{REF} - V_D}{R_s} - \frac{V_{IO}}{R_s}$$

- Final limit current  $I_{L3}$

The limit current for  $V_o = 0$  when  $R_2 \gg R_1$  is the point where the voltages on either side of  $R_s$  and on either side of  $R_5$  are biased.

$$R_s I_{L3} = \frac{R_4 R_5 V_{REF} - R_3 R_5 V_D - R_4 R_5 V_D}{R_3 R_4 + R_3 R_5 + R_4 R_5} - V_{IO}$$

$$\therefore I_{L3} = \frac{1}{R_s} \frac{1}{1 + (R_3 // R_4) / R_5} \left( \frac{R_4}{R_3 + R_4} V_{REF} - V_D \right) - \frac{V_{IO}}{R_s} \quad (2) \text{ Eq.}$$

$R_3 // R_4$  is the resistance formed by  $R_3$  and  $R_4$  in parallel ( $R_3 R_4 / (R_3 + R_4)$ ). When  $R_3 // R_4 \ll R_5$ , equation (2) becomes:

$$I_{L3} = \frac{1}{R_s} \left( \frac{R_4}{R_3 + R_4} V_{REF} - V_D \right) - \frac{V_{IO}}{R_s}$$

In addition to determining the limit current  $I_{L3}$  for  $V_o = 0$ ,  $R_3$ ,  $R_4$ ,  $R_5$ , and diode  $D$  also operate as a starter when the power is turned on.

- Starter circuit

The figure below shows the case when the starter circuit formed by  $R_3$ ,  $R_4$ ,  $R_5$ , and  $D$  is not present. The output current  $I_o$  after the operation of the current limiting circuit is:

$$I_o = \frac{R_1}{R_1 + R_2} \frac{V_o}{R_s} - \frac{V_{IO}}{R_s}$$

When  $V_o = 0$  such as when the power is turned on, the output current  $I_o = -V_{IO} / R_s$  and, if the offset voltage  $V_{IO}$  is positive, the output current is limited to being negative and therefore the output voltage does not rise. Accordingly, if using a fallback system with a detection resistor inserted in the output, always include a starter circuit, expect in the cases described later.

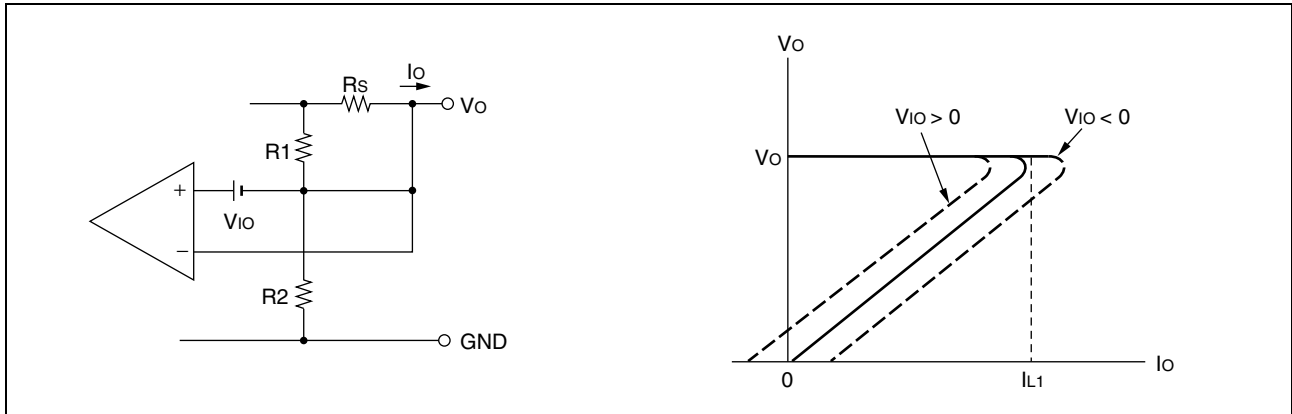

## (2) Example that does not use a diode

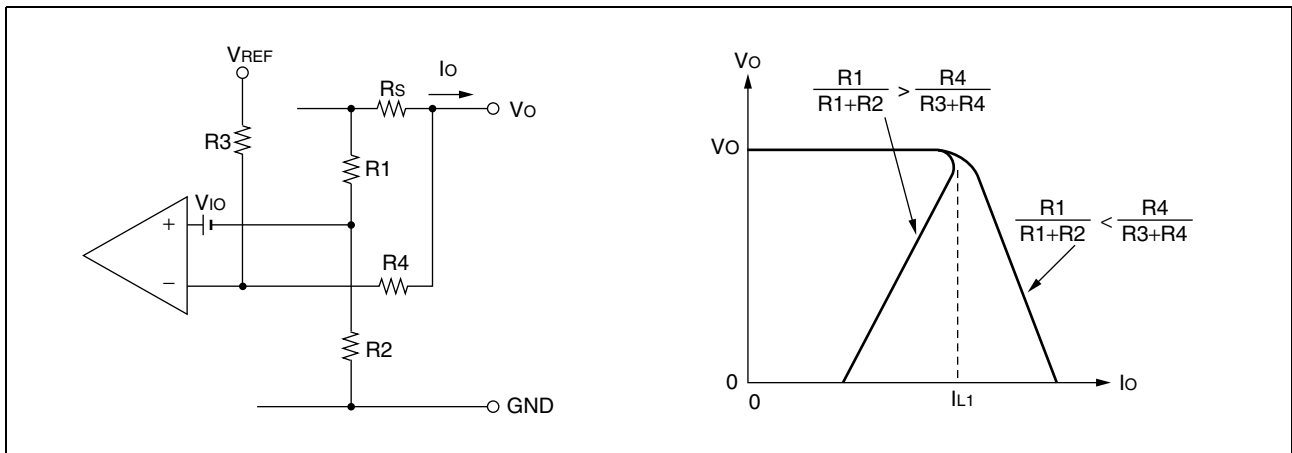

The output current  $I_o$  after current limiting is:

$$I_o = \frac{1}{R_s} \left[ \left( \frac{R_1}{R_1 + R_2} - \frac{R_4}{R_3 + R_4} \right) V_o + \frac{R_4}{R_3 + R_4} V_{REF} - V_{IO} \right] \quad (R_2 \gg R_1)$$

In this case, a current flows into the reference voltage source via  $R_3$  and  $R_4$  if  $V_o > V_{REF}$ . To maintain the stability of the reference voltage, design the circuit such that this does not exceed  $200 \mu A$ .

### (3) When an external stabilized negative power supply is present

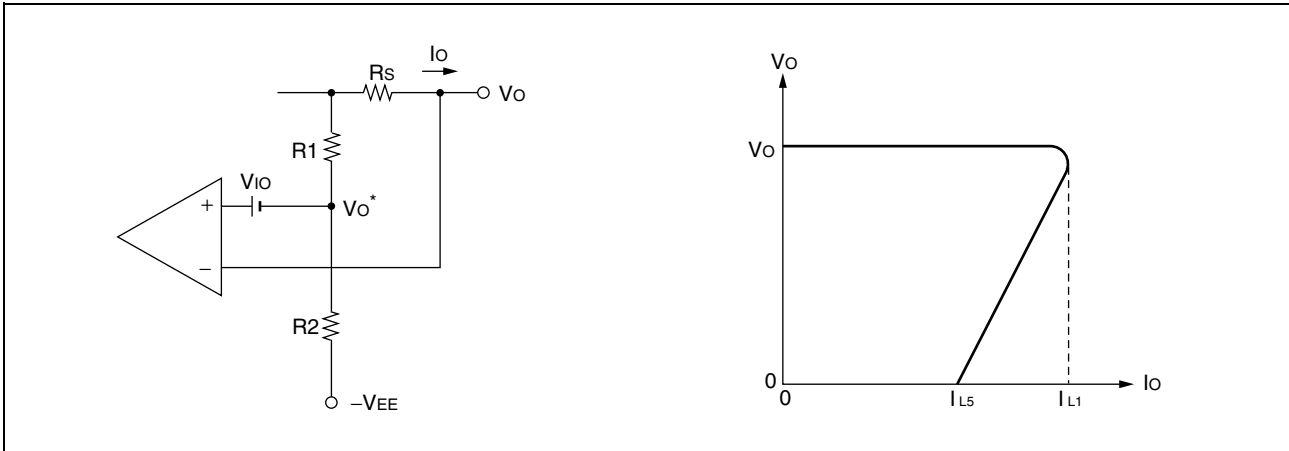

The output current  $I_o$  after current limiting is:

$$I_o = \frac{1}{R_s} \frac{R_1}{R_1 + R_2} (V_o + V_{EE}) - \frac{V_{IO}}{R_s} \quad (R_2 \gg R_1)$$

If the output is momentarily shorted,  $V_o^*$  goes briefly negative. In this case, set the voltage across  $R_1$  to 300 mV or less to ensure that a voltage of less than -0.3 V is not applied to the op-amp input.

## 6. Example Power Supply Voltage Supply Circuit

### (1) Supplied via a Zener diode

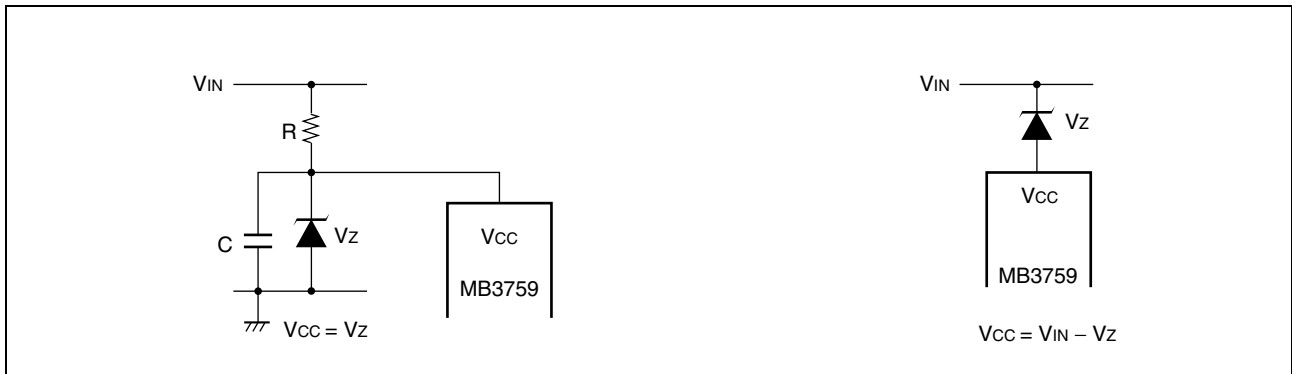

### (2) Supplied via a three-terminal regulator

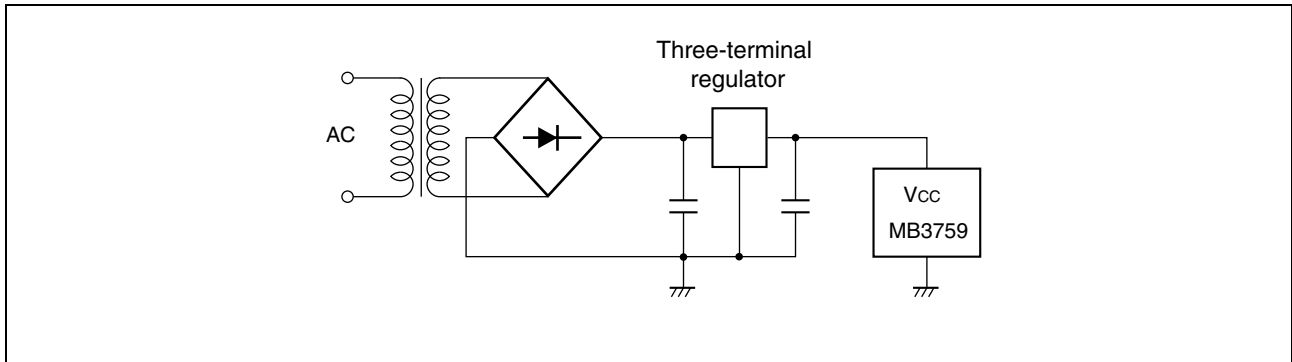

## 7. Example Protection Circuit for Output Transistor

Due to its monolithic IC characteristics, applying a negative voltage greater than the diode voltage ( $\approx 0.5\text{ V}$ ) to the substrate (pin 7) of the MB3759 causes a parasitic effect in the IC which can result in misoperation.

Accordingly, the following measures are required if driving a transformer or similar directly from the output transistor of the IC.

### (1) Protect the output transistor from the parasitic effect by using a Schottky barrier diode.

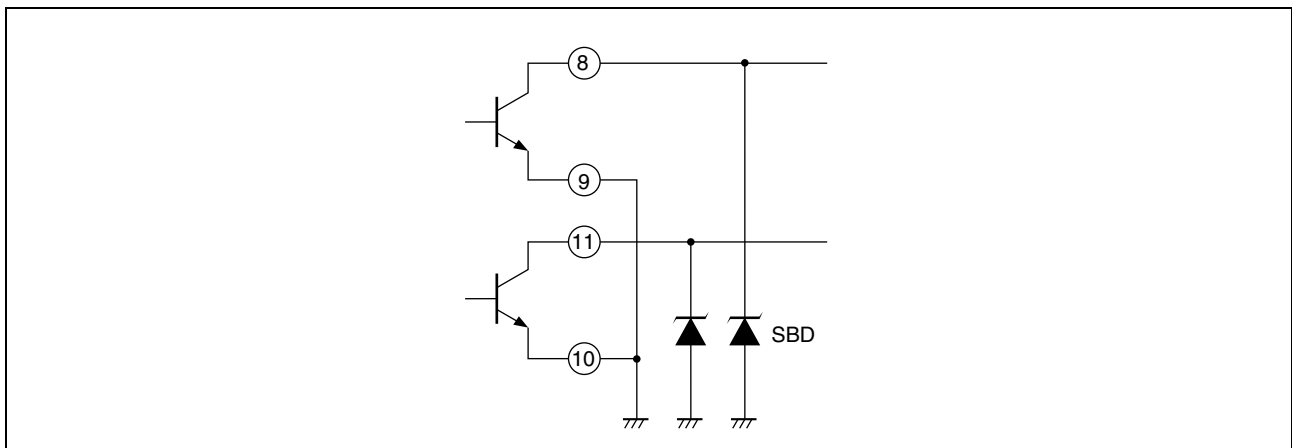

(2) Provide a bias at the anode-side of the diode to clamp the low level side of the transistor.

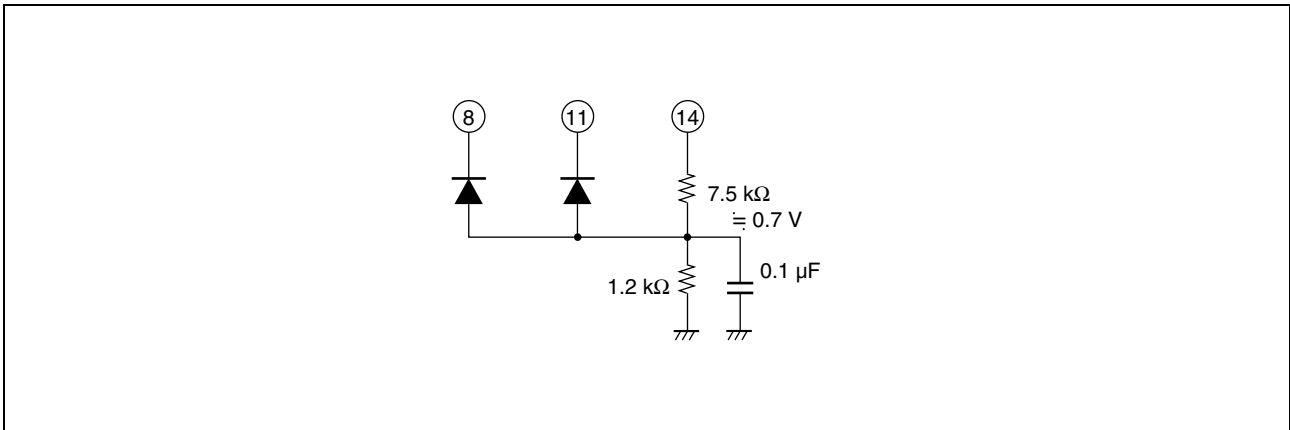

(3) Drive the transformer via a buffer transistor.

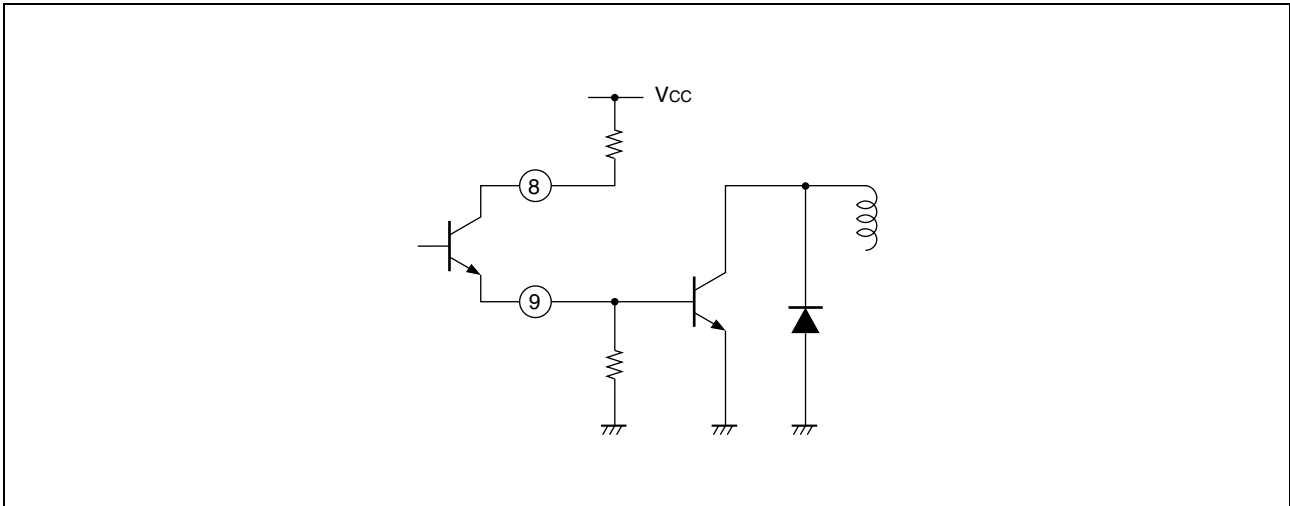

## 8. Typical Application

### (1) Chopper regulator

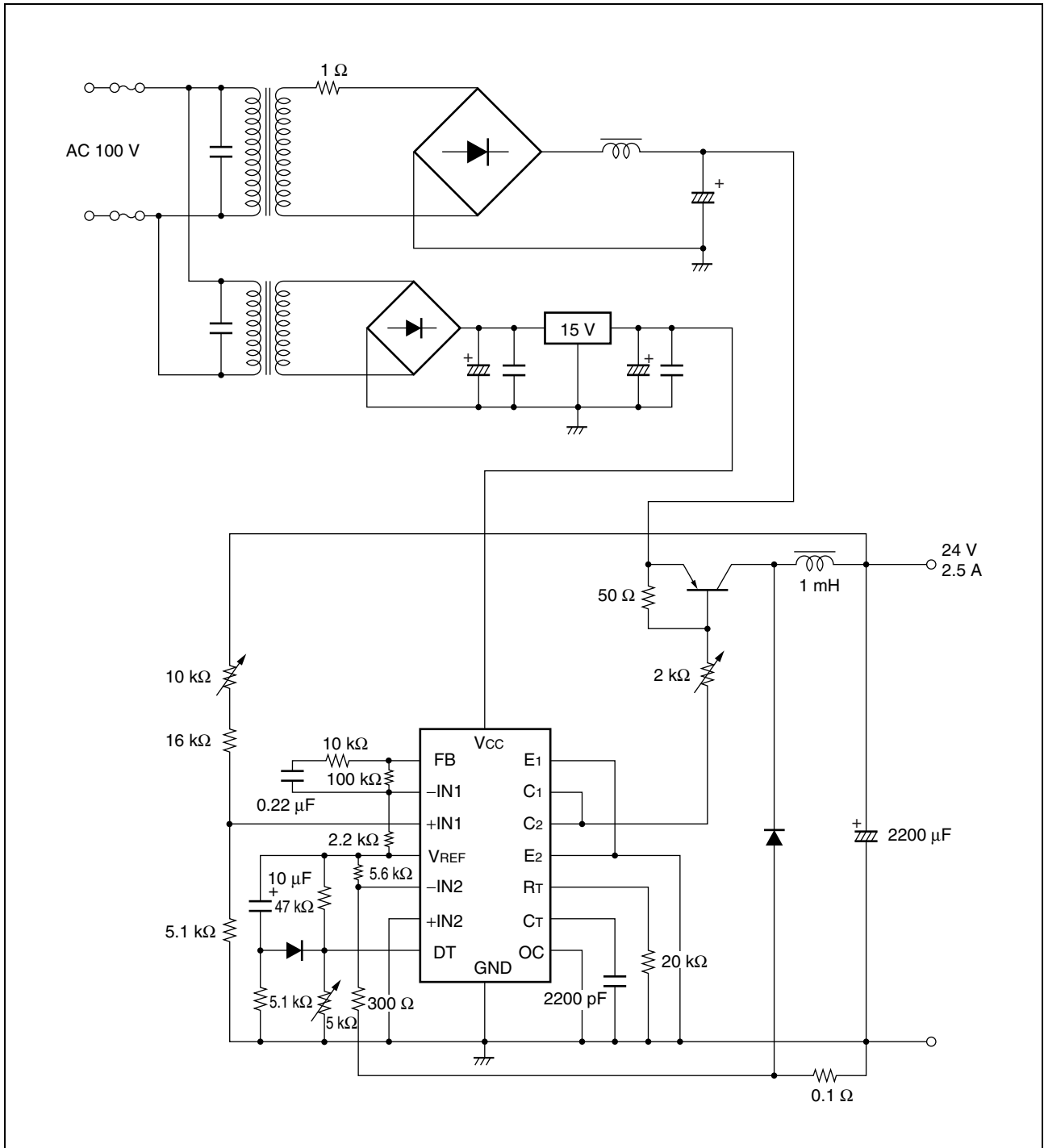

## (2) Inverter regulator

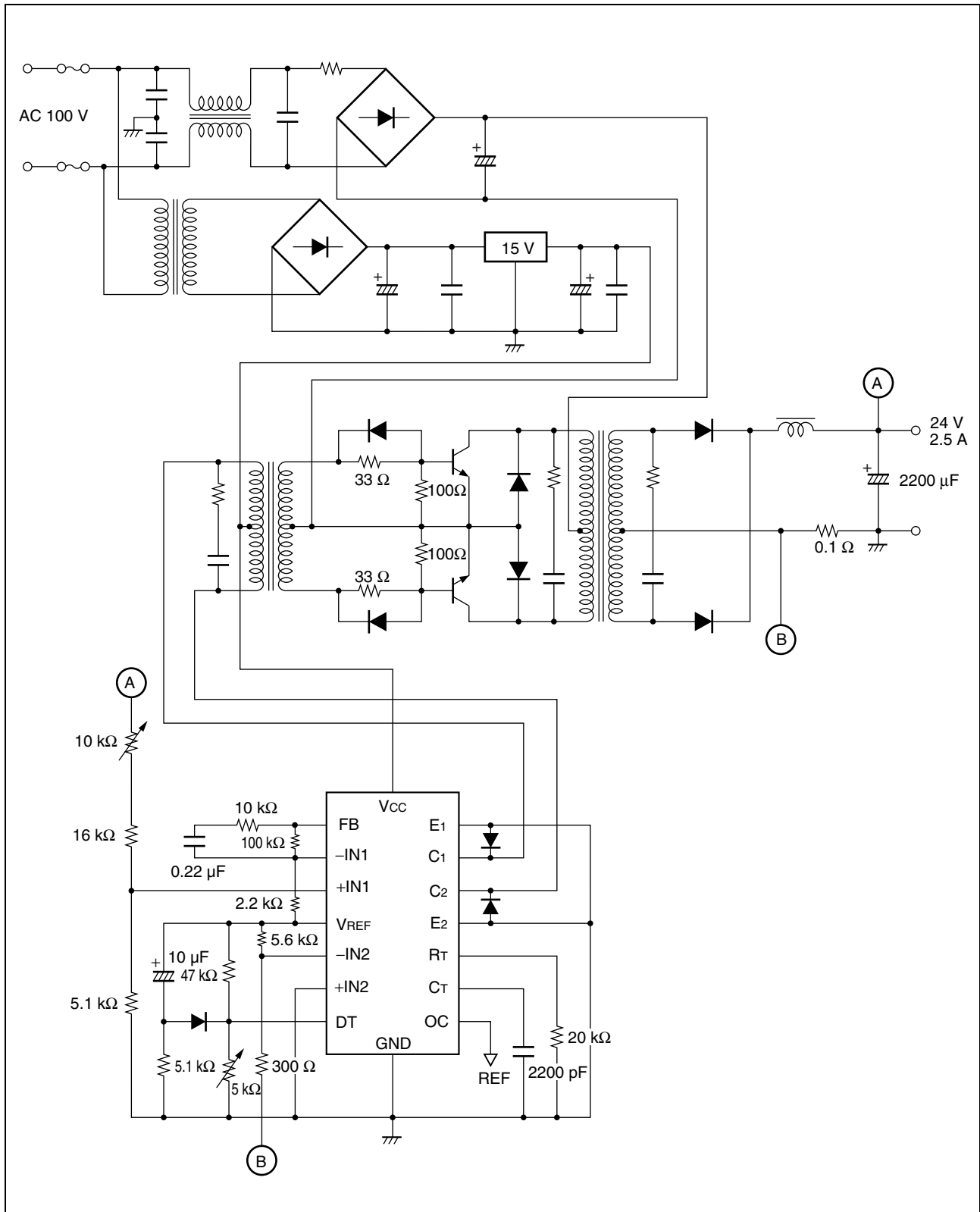

## ■ NOTES ON USE

- Take account of common impedance when designing the earth line on a printed wiring board.
- Take measures against static electricity.
  - For semiconductors, use antistatic or conductive containers.
  - When storing or carrying a printed circuit board after chip mounting, put it in a conductive bag or container.
  - The work table, tools and measuring instruments must be grounded.
  - The worker must put on a grounding device containing 250 k $\Omega$  to 1 M $\Omega$  resistors in series.
- Do not apply a negative voltage
  - Applying a negative voltage of  $-0.3$  V or less to an LSI may generate a parasitic transistor, resulting in malfunction.



## ■ ORDERING INFORMATION

Part number	Package	Remarks
MB3759PF	16-pin plastic SOP (FPT-16P-M06)	

## ■ RoHS Compliance Information of Lead (Pb) Free version

The LSI products of FUJITSU SEMICONDUCTOR with "E1" are compliant with RoHS Directive, and has observed the standard of lead, cadmium, mercury, Hexavalent chromium, polybrominated biphenyls (PBB), and polybrominated diphenyl ethers (PBDE).

The product that conforms to this standard is added "E1" at the end of the part number.

## ■ MARKING FORMAT (Lead Free version)

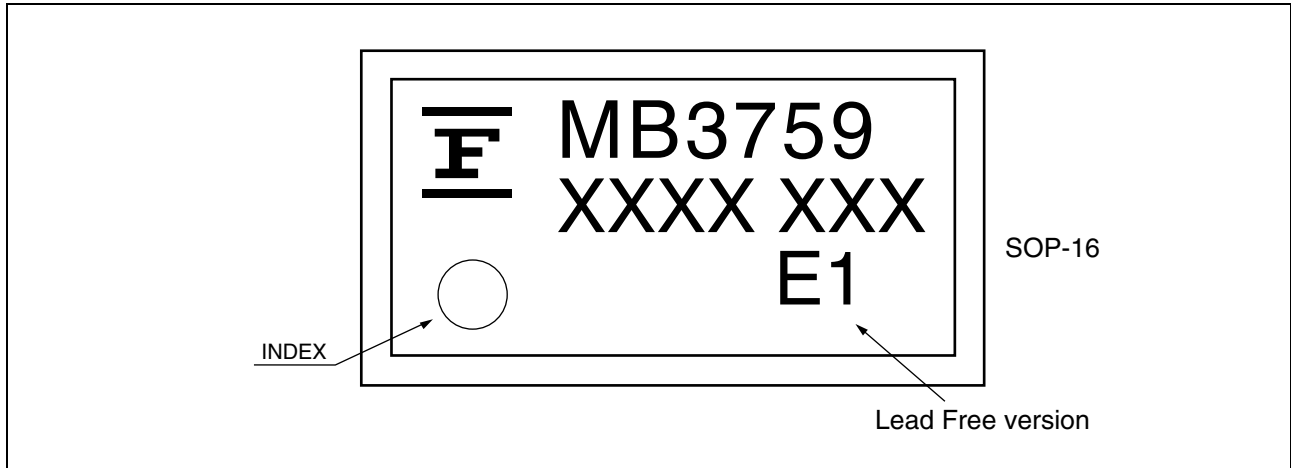

## ■ LABELING SAMPLE (Lead free version)

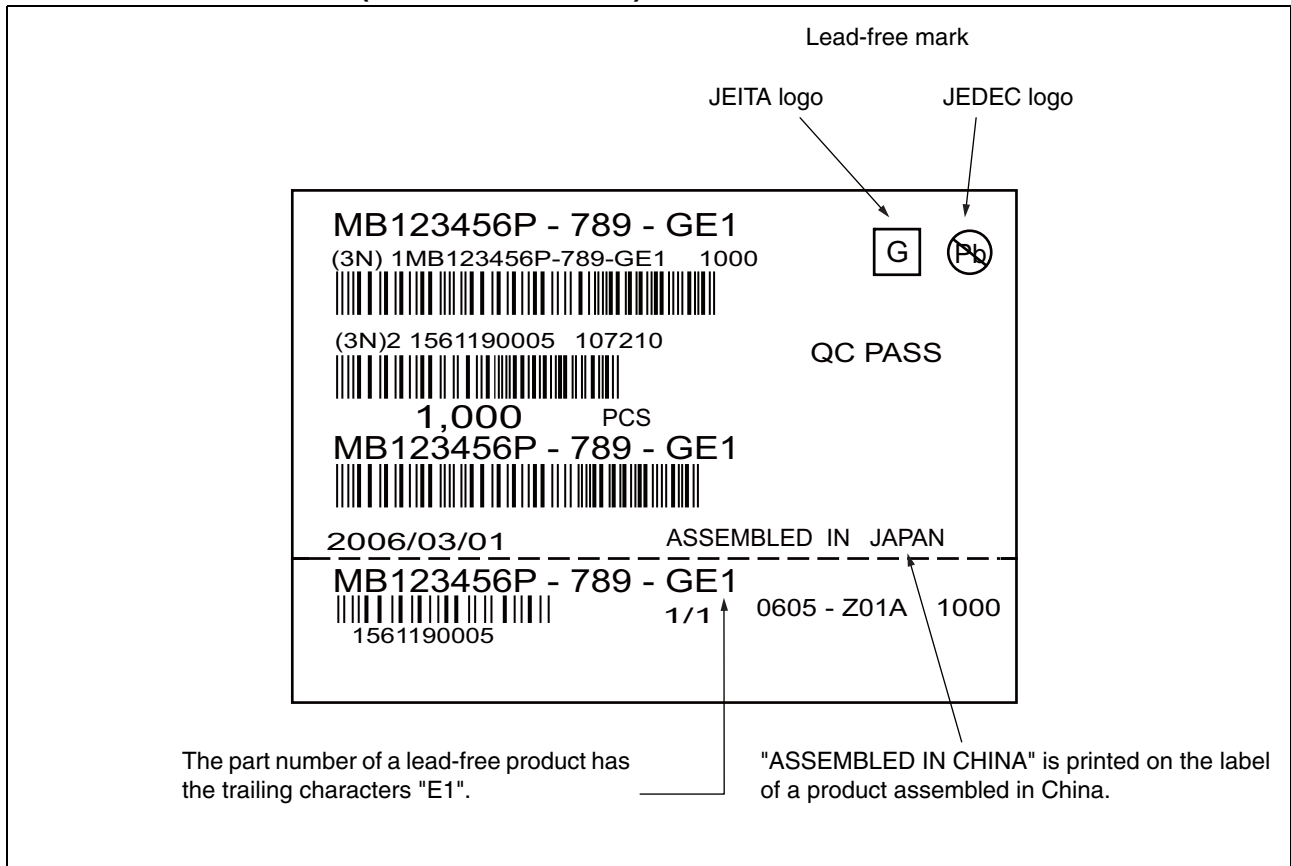

## ■ MB3759PF RECOMMENDED CONDITIONS OF MOISTURE SENSITIVITY LEVEL

Item	Condition	
Mounting Method	IR (infrared reflow) , Manual soldering (partial heating method)	
Mounting times	2 times	
Storage period	Before opening	Please use it within two years after Manufacture.
	From opening to the 2nd reflow	Less than 8 days
	When the storage period after opening was exceeded	Please processes within 8 days after baking (125 °C, 24H)
Storage conditions	5 °C to 30 °C, 70%RH or less (the lowest possible humidity)	

### [Temperature Profile for FJ Standard IR Reflow]

#### (1) IR (infrared reflow)

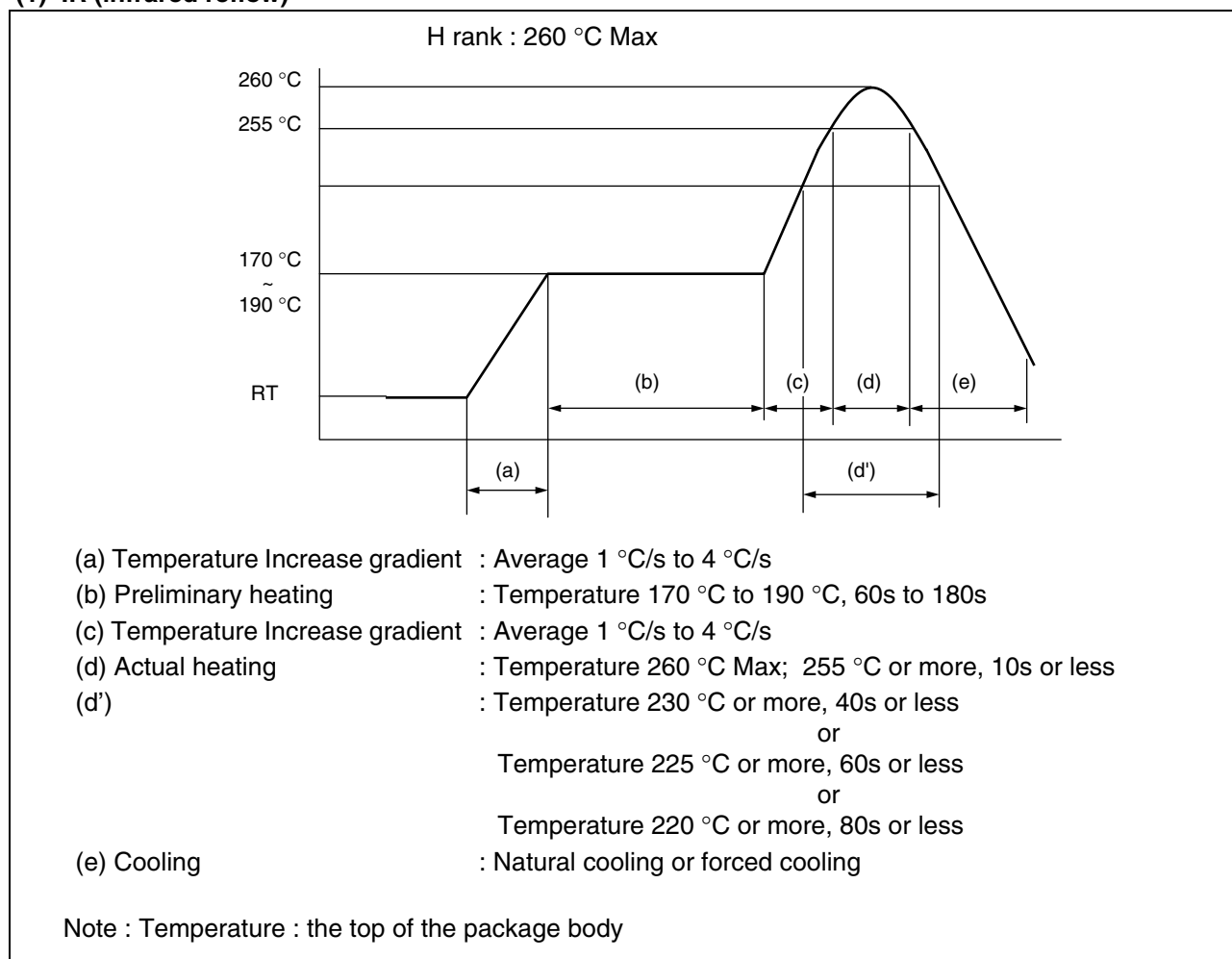

#### (2) Manual soldering (partial heating method)

Conditions : Temperature 400 °C Max

Times : 5 s max/pin

# MB3759

## PACKAGE DIMENSION

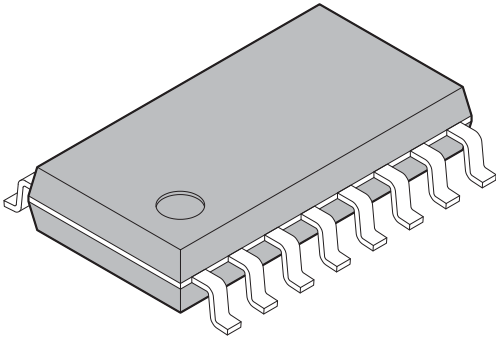
 <p>16-pin plastic SOP</p> <p>(FPT-16P-M06)</p>	Lead pitch	1.27 mm
	Package width × package length	5.3 × 10.15 mm
	Lead shape	Gullwing
	Sealing method	Plastic mold
	Mounting height	2.25 mm MAX
	Weight	0.20 g
	Code (Reference)	P-SOP16-5.3×10.15-1.27

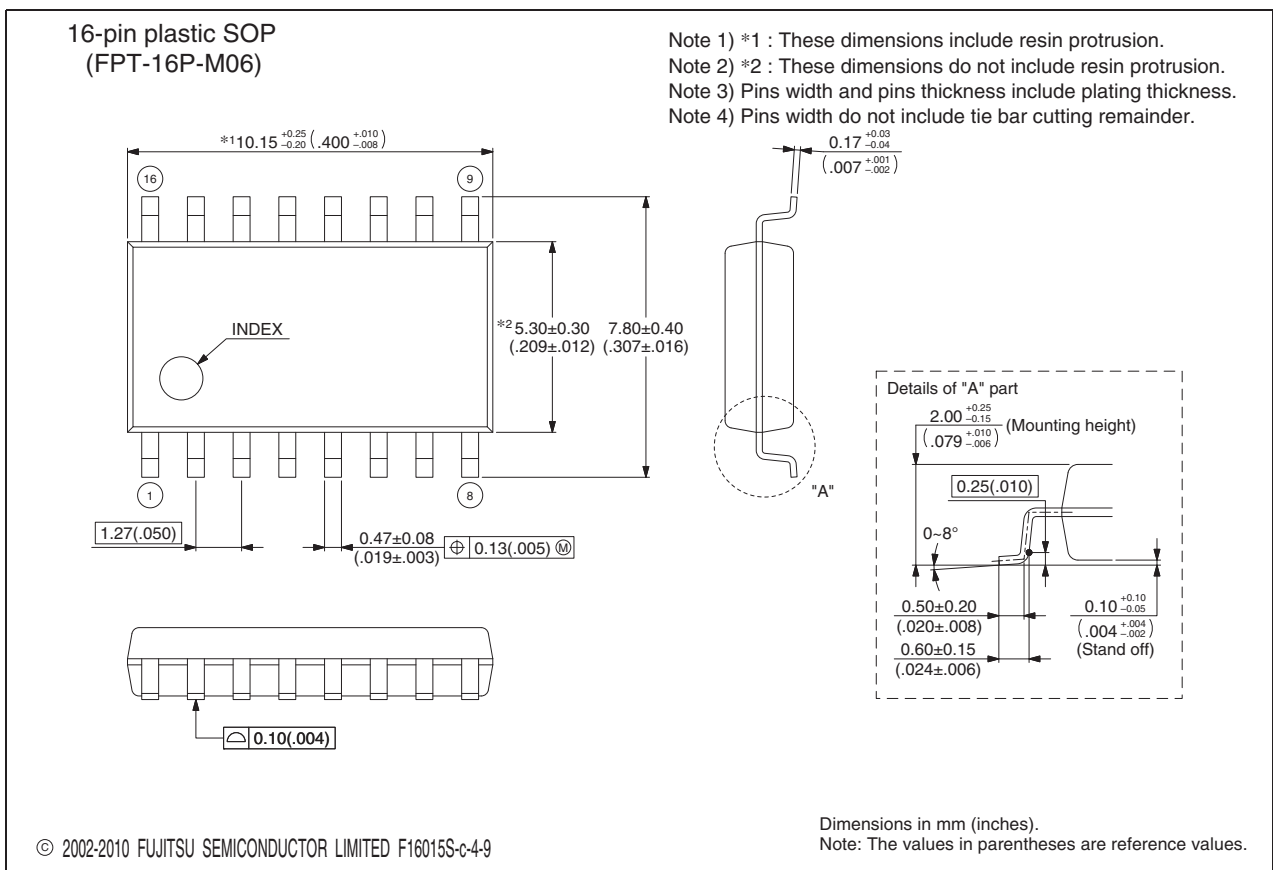

Please check the latest package dimension at the following URL.  
<http://edevice.fujitsu.com/package/en-search/>

**MEMO**

**MEMO**

**MEMO**

## FUJITSU SEMICONDUCTOR LIMITED

Nomura Fudosan Shin-yokohama Bldg. 10-23, Shin-yokohama 2-Chome,  
Kohoku-ku Yokohama Kanagawa 222-0033, Japan

Tel: +81-45-415-5858

<http://jp.fujitsu.com/fsl/en/>

*For further information please contact:*

### North and South America

FUJITSU SEMICONDUCTOR AMERICA, INC.

1250 E. Arques Avenue, M/S 333

Sunnyvale, CA 94085-5401, U.S.A.

Tel: +1-408-737-5600 Fax: +1-408-737-5999

<http://us.fujitsu.com/micro/>

### Asia Pacific

FUJITSU SEMICONDUCTOR ASIA PTE. LTD.

151 Lorong Chuan,

#05-08 New Tech Park 556741 Singapore

Tel : +65-6281-0770 Fax : +65-6281-0220

<http://www.fujitsu.com/sg/services/micro/semiconductor/>

### Europe

FUJITSU SEMICONDUCTOR EUROPE GmbH

Pittlerstrasse 47, 63225 Langen, Germany

Tel: +49-6103-690-0 Fax: +49-6103-690-122

<http://emea.fujitsu.com/semiconductor/>

FUJITSU SEMICONDUCTOR SHANGHAI CO., LTD.

Rm. 3102, Bund Center, No.222 Yan An Road (E),

Shanghai 200002, China

Tel : +86-21-6146-3688 Fax : +86-21-6335-1605

<http://cn.fujitsu.com/fss/>

### Korea

FUJITSU SEMICONDUCTOR KOREA LTD.

902 Kosmo Tower Building, 1002 Daechi-Dong,

Gangnam-Gu, Seoul 135-280, Republic of Korea

Tel: +82-2-3484-7100 Fax: +82-2-3484-7111

<http://kr.fujitsu.com/fsk/>

FUJITSU SEMICONDUCTOR PACIFIC ASIA LTD.

10/F., World Commerce Centre, 11 Canton Road,

Tsimshatsui, Kowloon, Hong Kong

Tel : +852-2377-0226 Fax : +852-2376-3269

<http://cn.fujitsu.com/fsp/>

Specifications are subject to change without notice. For further information please contact each office.

### All Rights Reserved.

The contents of this document are subject to change without notice.

Customers are advised to consult with sales representatives before ordering.

The information, such as descriptions of function and application circuit examples, in this document are presented solely for the purpose of reference to show examples of operations and uses of FUJITSU SEMICONDUCTOR device; FUJITSU SEMICONDUCTOR does not warrant proper operation of the device with respect to use based on such information. When you develop equipment incorporating the device based on such information, you must assume any responsibility arising out of such use of the information.

FUJITSU SEMICONDUCTOR assumes no liability for any damages whatsoever arising out of the use of the information.

Any information in this document, including descriptions of function and schematic diagrams, shall not be construed as license of the use or exercise of any intellectual property right, such as patent right or copyright, or any other right of FUJITSU SEMICONDUCTOR or any third party or does FUJITSU SEMICONDUCTOR warrant non-infringement of any third-party's intellectual property right or other right by using such information. FUJITSU SEMICONDUCTOR assumes no liability for any infringement of the intellectual property rights or other rights of third parties which would result from the use of information contained herein.

The products described in this document are designed, developed and manufactured as contemplated for general use, including without limitation, ordinary industrial use, general office use, personal use, and household use, but are not designed, developed and manufactured as contemplated (1) for use accompanying fatal risks or dangers that, unless extremely high safety is secured, could have a serious effect to the public, and could lead directly to death, personal injury, severe physical damage or other loss (i.e., nuclear reaction control in nuclear facility, aircraft flight control, air traffic control, mass transport control, medical life support system, missile launch control in weapon system), or (2) for use requiring extremely high reliability (i.e., submersible repeater and artificial satellite).

Please note that FUJITSU SEMICONDUCTOR will not be liable against you and/or any third party for any claims or damages arising in connection with above-mentioned uses of the products.

Any semiconductor devices have an inherent chance of failure. You must protect against injury, damage or loss from such failures by incorporating safety design measures into your facility and equipment such as redundancy, fire protection, and prevention of over-current levels and other abnormal operating conditions.

Exportation/release of any products described in this document may require necessary procedures in accordance with the regulations of the Foreign Exchange and Foreign Trade Control Law of Japan and/or US export control laws.

The company names and brand names herein are the trademarks or registered trademarks of their respective owners.

Edited: Sales Promotion Department