

LM2638 Motherboard Power Supply Solution with a 5-Bit Programmable Switching Controller and Two Linear Regulator Controllers

Check for Samples: [LM2638](#)

FEATURES

- Provides 3 regulated voltages
- Power Good flag and output enable
- Charge pump pin
 - *Switching Section*
- Synchronous rectification
- 5-bit DAC programmable down to 1.3V
- Typical $\pm 1\%$ DAC tolerance
- Switching frequency: 50 kHz to 1 MHz
- Over-voltage protection
- Two methods of over-current protection
- Adaptive non-overlapping FET gate drives
- Soft start without external capacitor

– *Linear Section*

- N-FET and NPN drive capability
- Ultra fast response speed
- Under voltage latch-off at 0.63V
- Output voltages default to 1.5V and 2.5V yet adjustable

APPLICATIONS

- Embedded power supplies for motherboards
- Triple DC/DC power supplies
- Programmable high current DC/DC power supply

DESCRIPTION

The LM2638 provides a comprehensive embedded power supply solution for motherboards hosting high performance MPUs such as Pentium™ II, M II™, K6™-2 and other similar high performance MPUs. The LM2638 incorporates a 5-bit programmable, synchronous buck switching controller and two high-speed linear regulator controllers in a 24-pin SO package. In a typical application, the switching controller supplies the MPU core, and the linear regulator controllers supply the GTL+ bus and the clock or graphics chip core. A charge pump pin helps provide the necessary voltage to power the linear sections when 12V is shut off during system standby such as STR mode.

Switching Section — The switching regulator controller features an Intel-compatible, 5-bit programmable output voltage, over-current and over-voltage protection, a power good signal, and a logic-controlled output enable. There are two user-selectable over-current protection methods. One provides accurate over-current protection with the use of an external sense resistor. The other saves cost by taking advantage of the r_{DS_ON} of the high-side FET. When there is an over voltage, the controller turns off the high side FET and turns on the low side.

Linear Section — The two linear regulator controllers feature wide control bandwidth, N-FET and NPN transistor driving capability and an adjustable output. The wide control bandwidth makes meeting the GTL+ bus transient response requirement an easy job. In minimum configuration, the two controllers default to 1.5V and 1.25V respectively.

Both linear controllers have under voltage latch-off.



Please be aware that an important notice concerning availability, standard warranty, and use in critical applications of Texas Instruments semiconductor products and disclaimers thereto appears at the end of this data sheet.

K6 is a trademark of Advanced Micro Devices, Inc..

M II is a trademark of Cyrix Corporation.

Pentium is a trademark of Intel Corporation.

All other trademarks are the property of their respective owners.

Pin Configuration

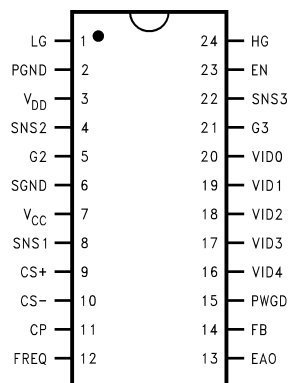

Figure 1. 24-Lead SOIC (Top View)



These devices have limited built-in ESD protection. The leads should be shorted together or the device placed in conductive foam during storage or handling to prevent electrostatic damage to the MOS gates.

Absolute Maximum Ratings ⁽¹⁾

V _{CC}	7V
V _{DD}	17V
Junction Temperature	150°C
Power Dissipation ⁽²⁾	1.6W
Storage Temperature	-65°C to +150°C
ESD Susceptibility	3 kV
Soldering Time, Temperature (10 sec.)	300°C

- (1) **Absolute Maximum Ratings** are limits beyond which damage to the device may occur. **Operating ratings** are conditions under which the device operates correctly. **Operating Ratings** do not imply guaranteed performance limits.
- (2) Maximum allowable power dissipation is a function of the maximum junction temperature, T_{JMAX}, the junction-to-ambient thermal resistance, θ_{JA}, and the ambient temperature, T_A. The maximum allowable power dissipation at any ambient temperature is calculated using: $P_{MAX} = (T_{JMAX} - T_A) / \theta_{JA}$. The junction-to-ambient thermal resistance, θ_{JA}, for LM2638 is 78°C/W. For a T_{JMAX} of 150°C and T_A of 25°C, the maximum allowable power dissipation is 1.6W.

Operating Ratings ⁽¹⁾

V _{CC}	4.75V to 5.25V
Junction Temperature Range	0°C to +125°C

- (1) **Absolute Maximum Ratings** are limits beyond which damage to the device may occur. **Operating ratings** are conditions under which the device operates correctly. **Operating Ratings** do not imply guaranteed performance limits.

Electrical Characteristics

$V_{CC} = 5V$, $V_{DD} = 12V$ unless otherwise specified. Typicals and limits appearing in plain type apply for $T_A = T_J = +25^\circ C$. Limits appearing in **boldface** type apply over the $0^\circ C$ to $+70^\circ C$ range.

Symbol	Parameter	Conditions	Min	Typ	Max	Units
I_{EN}	EN Pin Internal Pull-up Current		60	90	140	μA
I_{CC}	Operating V_{CC} Current	EN = 5V, VID = 10111		6	7.5	mA
I_{Q_VCC}	V_{CC} Shutdown Current	EN = 0V, VID Pins Floating		1.5	3	mA
I_{Q_VDD}	V_{DD} Shutdown Current	EN = 0V, VID Pins Floating		4		μA
R_{DS_CP}	CP Pin Resistance	High Side FET		100		Ω
		Low Side FET		10		
SWITCHING SECTION						
V_{DACOUT}	5-Bit DAC Output Voltage	(1)	<i>N</i>-1.5%	<i>N</i>	<i>N</i>+1.5%	V
I_{VID}	VID Pins Internal Pull-up Current		60	90	140	μA
f_{OSC}	Oscillator Frequency	RT = 100 k Ω	204	245	286	kHz
		RT = 25 k Ω		1000		
D_{MAX}	Maximum Duty Cycle			100		%
D_{MIN}	Minimum Duty Cycle			0		%
R_{SNS1}	SNS1 Pin Resistance to Ground		8.5	10	13	k Ω
R_{DS_SRC}	Gate Driver Resistance When Sourcing Current			6		Ω
R_{DS_SINK}	Gate Driver Resistance When Sinking Current			1.5		Ω
V_{CC_TH1}	V_{CC} Power-On-Reset Threshold			4.0	4.3	V
V_{CC_TH2}	V_{CC} Shutdown Threshold		3.0	3.6		V
V_{DAC_IH}	DAC Input High Voltage		3.5			V
V_{DAC_IL}	DAC Input Low Voltage				1.3	V
GA	Error Amplifier DC Gain			76		dB
BW_{EA}	Error Amplifier Unity Gain Bandwidth			5		MHz
V_{RAMP_L}	Ramp Signal Valley Voltage			1.25		V
V_{RAMP_H}	Ramp Signal Peak Voltage			3.25		V
t_{SS}	Soft Start Time			4096		Clock Cycles
D_{STEP_SS}	Duty Cycle Step Change during Soft Start			12.5		%
t_{PWGD}	PWGD Response Time	SNS1 Rises from 0V to Rated Output Voltage	2	8.4	15	μs
t_{PWBAD}	PWGD Response Time	SNS1 Falls from Rated Output Voltage to 0V	2	3.4	10	μs
V_{PWGD_HI}	PWGD High Trip Point	% Above Rated Output Voltage When Output Voltage \uparrow		11.5	13	%
		% Above Rated Output Voltage When Output Voltage \downarrow (2)	5	7	9	
V_{PWGD_LO}	PWGD Low Trip Point	% Below Rated Output Voltage When Output Voltage \uparrow		2.6	6	%
		% Below Rated Output Voltage When Output Voltage \downarrow (2)	6	9.5	13	
V_{OVP_TRP}	Over-Voltage Trip Point	% SNS1 Above Rated Output	15	25	35	%
I_{CS+}	CS+ Pin Sink Current	CS+ = 5V, CS- = 4.8V	126	185	244	μA

(1) The letter **N** stands for the typical output voltages appearing in **italic boldface** type in [Table 1](#).

(2) The output level of the PWGD pin is a logic AND of the power good function of the switching section, the 1.5V section and the 1.25V section. For the switching section, the power good is a window. For the two linear sections, the power good is a threshold with some hysteresis.

Electrical Characteristics (continued)

$V_{CC} = 5V$, $V_{DD} = 12V$ unless otherwise specified. Typicals and limits appearing in plain type apply for $T_A = T_J = +25^\circ C$. Limits appearing in **boldface** type apply over the $0^\circ C$ to $+70^\circ C$ range.

Symbol	Parameter	Conditions	Min	Typ	Max	Units
V_{OCP}	Over-Current Trip Point (CS+ and CS- Differential Voltage)	CS+ = 2V, CS- Drops from 2V	41	55	69	mV
1.5V LDO CONTROLLER SECTION						
V_{SNS2}	SNS2 Voltage	$V_{DD} = 12V$, $V_{CC} = 4.75V$ to $5.25V$, $I_{G2} = 0$ mA to 20 mA	1.463	1.5	1.538	V
R_{OUT2}	Output Resistance			200		Ω
I_{SNS2}	SNS2 Pin Bias Current	When Regulating		21		μA
V_{PWGD_HI}	PWGD High Trip Point	(2)		0.63		V
V_{PWGD_LO}	PWGD Low Trip Point	(2)		0.44		V
1.25V LDO CONTROLLER SECTION						
V_{SNS3}	SNS3 Voltage	$V_{DD} = 12V$, $V_{CC} = 4.75V$ to $5.25V$, $I_{G3} = 0$ mA to 20 mA	1.219	1.25	1.281	V
R_{OUT3}	Output Resistance			200		Ω
I_{SNS3}	SNS3 Pin Bias Current	When Regulating		0		μA
V_{PWGD_HI}	PWGD High Trip Point	(2)		0.63		V
V_{PWGD_LO}	PWGD Low Trip Point	(3)		0.44		V

- (3) The output level of the PWGD pin is a logic AND of the power good function of the switching section, the 1.5V section and the 1.25V section. For the switching section, the power good is a window. For the two linear sections, the power good is a threshold with some hysteresis.

Table 1. 5-Bit DAC Output Voltage Table ($V_{CC} = 5V$, $V_{DD} = 12V \pm 5\%$, $T_A = 25^\circ C$, Test Mode)

Symbol	Parameter	Conditions	Typical	Units
V_{DACOUT}	5-Bit DAC Output Voltages for Different VID Codes	VID4:0 = 01111	1.30	V
		VID4:0 = 01110	1.35	
		VID4:0 = 01101	1.40	
		VID4:0 = 01100	1.45	
		VID4:0 = 01011	1.50	
		VID4:0 = 01010	1.55	
		VID4:0 = 01001	1.60	
		VID4:0 = 01000	1.65	
		VID4:0 = 00111	1.70	
		VID4:0 = 00110	1.75	
		VID4:0 = 00101	1.80	
		VID4:0 = 00100	1.85	
		VID4:0 = 00011	1.90	
		VID4:0 = 00010	1.95	
		VID4:0 = 00001	2.00	
		VID4:0 = 00000	2.05	
		VID4:0 = 11111	(shutdown)	
		VID4:0 = 11110	2.1	
		VID4:0 = 11101	2.2	
		VID4:0 = 11100	2.3	
		VID4:0 = 11011	2.4	
		VID4:0 = 11010	2.5	
		VID4:0 = 11001	2.6	
		VID4:0 = 11000	2.7	
		VID4:0 = 10111	2.8	
		VID4:0 = 10110	2.9	
		VID4:0 = 10101	3.0	
		VID4:0 = 10100	3.1	
VID4:0 = 10011	3.2			
VID4:0 = 10010	3.3			
VID4:0 = 10001	3.4			
VID4:0 = 10000	3.5			

Table 2. Pin Description

Pin	Pin Name	Pin Function
1	LG	Low side N-FET gate driver output.
2	PGND	Ground for the two FET drivers of the switching section.
3	V_{DD}	Supply for the FET gate drivers. Usually tied to +12V.
4	SNS2	Feedback pin for the 1.5V linear regulator.
5	G2	Gate drive output for the external N-MOS of the fast 1.5V linear regulator.
6	SGND	Ground for internal signal circuitry and system ground reference.
7	V_{CC}	Supply voltage. Usually +5V.
8	SNS1	Output voltage monitor input for the switching regulator.
9	CS+	Switching regulator current sense input, positive node.
10	CS-	Switching regulator current sense input, negative node.
11	CP	Charge pump. Output is a square wave with 50% duty cycle. Amplitude is close to V_{CC} voltage.
12	FREQ	Switching frequency adjustment pin. An external resistor is needed to set the desired frequency.

Table 2. Pin Description (continued)

Pin	Pin Name	Pin Function
13	EAO	Output of the error amplifier. Used for compensating the switching regulator.
14	FB	Inverting input of the error amplifier. Used for compensating the switching regulator.
15	PWGD	Open collector Power Good signal.
16	VID4	5-Bit DAC input, MSB.
17	VID3	5-Bit DAC input.
18	VID2	5-Bit DAC input.
19	VID1	5-Bit DAC input.
20	VID0	5-Bit DAC input, LSB.
21	G3	Gate drive pin for the external N-MOS of the 1.25V linear regulator.
22	SNS3	Feedback pin for the 1.25V linear regulator.
23	EN	Output Enable. A logic low shuts the whole chip down.
24	HG	High side N-FET gate driver output.

Block Diagram

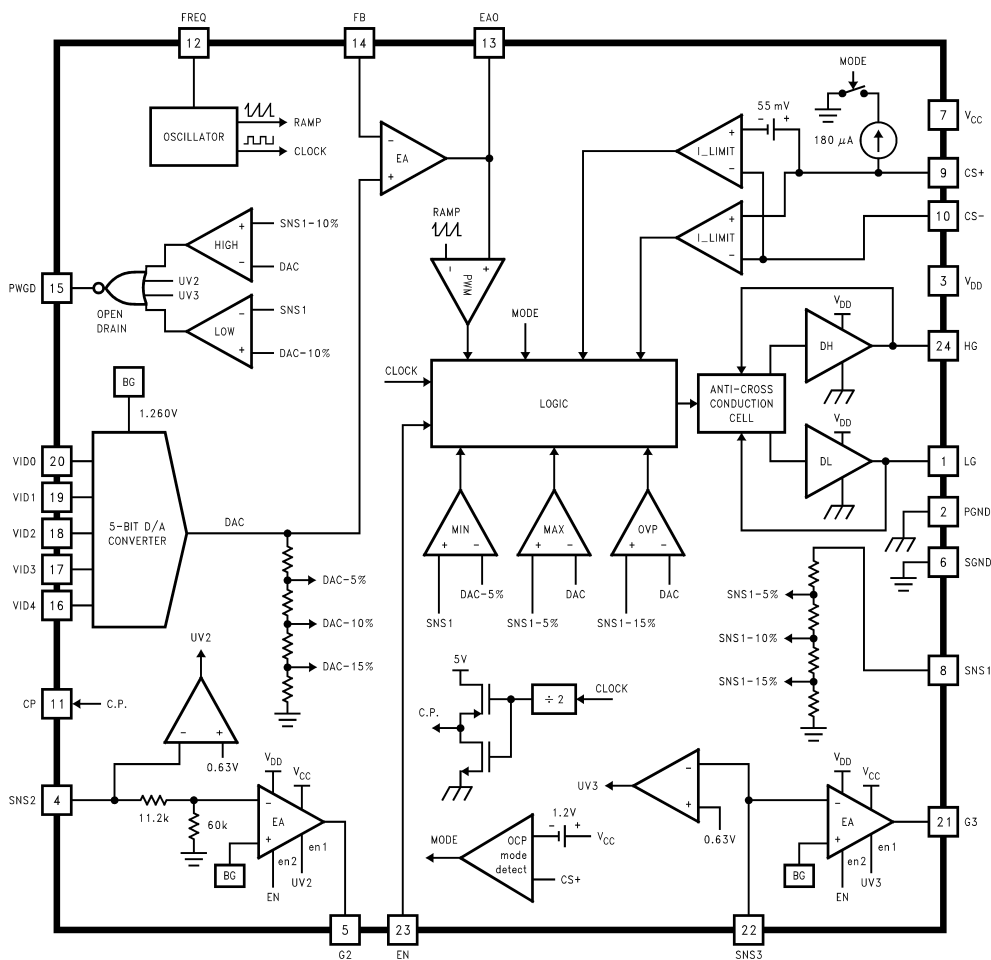

Test Circuit

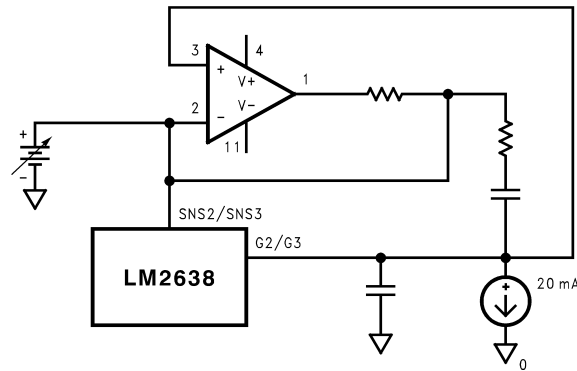

Figure 2. LDO Controller Test Circuit

Typical Application

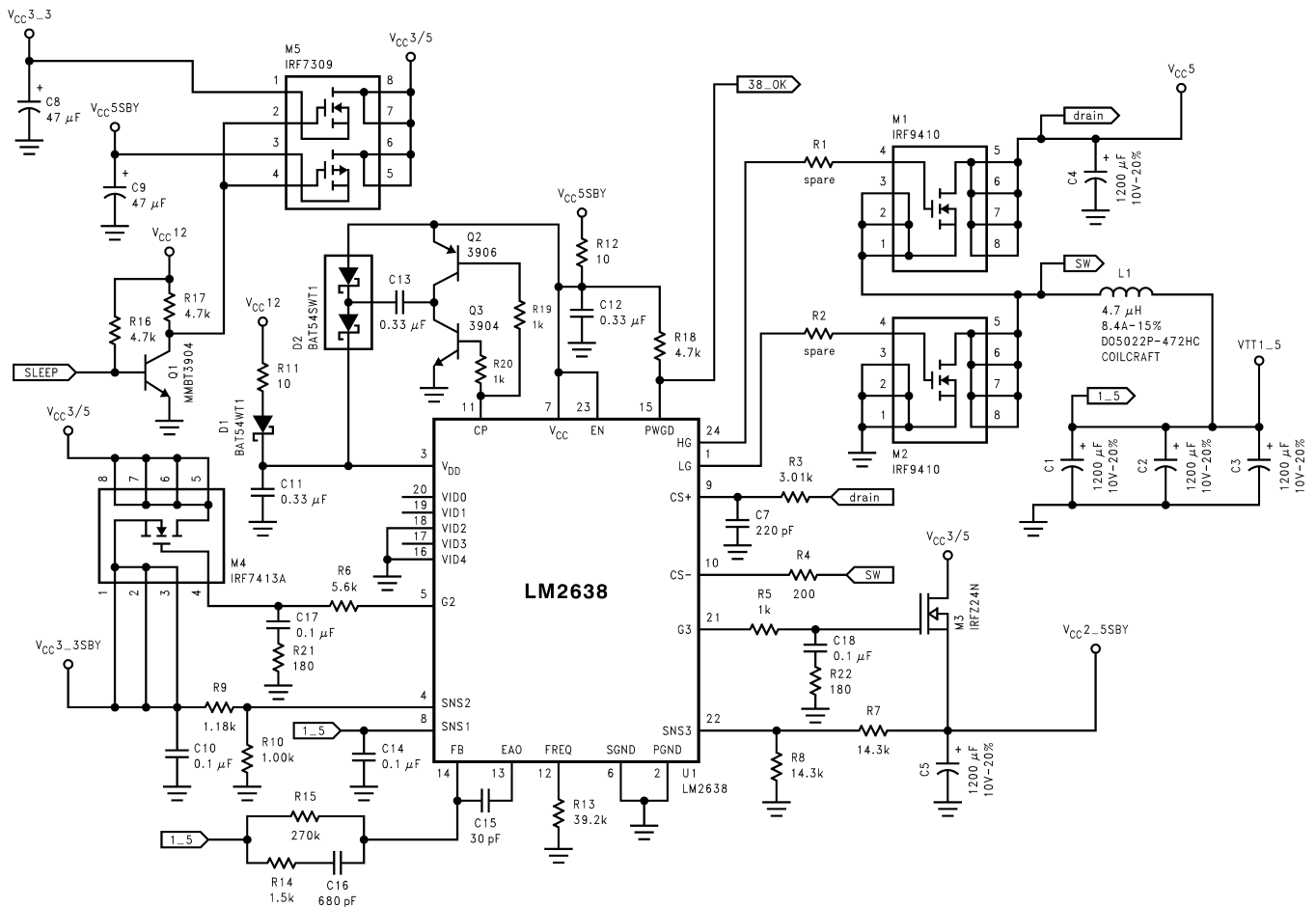

Figure 3. Using LM2638 to Supply GTL+ Bus (VTT, 1.5V, 5.6A), 2.5V Standby (V_{CC2_5SBY}, 2A Full Power and 180 mA Suspend) and 3.3V Standby (V_{CC3_3SBY}, 1.5A Full Power, 0.5A Suspend)

IMPORTANT NOTICE

Texas Instruments Incorporated and its subsidiaries (TI) reserve the right to make corrections, enhancements, improvements and other changes to its semiconductor products and services per JESD46, latest issue, and to discontinue any product or service per JESD48, latest issue. Buyers should obtain the latest relevant information before placing orders and should verify that such information is current and complete. All semiconductor products (also referred to herein as "components") are sold subject to TI's terms and conditions of sale supplied at the time of order acknowledgment.

TI warrants performance of its components to the specifications applicable at the time of sale, in accordance with the warranty in TI's terms and conditions of sale of semiconductor products. Testing and other quality control techniques are used to the extent TI deems necessary to support this warranty. Except where mandated by applicable law, testing of all parameters of each component is not necessarily performed.

TI assumes no liability for applications assistance or the design of Buyers' products. Buyers are responsible for their products and applications using TI components. To minimize the risks associated with Buyers' products and applications, Buyers should provide adequate design and operating safeguards.

TI does not warrant or represent that any license, either express or implied, is granted under any patent right, copyright, mask work right, or other intellectual property right relating to any combination, machine, or process in which TI components or services are used. Information published by TI regarding third-party products or services does not constitute a license to use such products or services or a warranty or endorsement thereof. Use of such information may require a license from a third party under the patents or other intellectual property of the third party, or a license from TI under the patents or other intellectual property of TI.

Reproduction of significant portions of TI information in TI data books or data sheets is permissible only if reproduction is without alteration and is accompanied by all associated warranties, conditions, limitations, and notices. TI is not responsible or liable for such altered documentation. Information of third parties may be subject to additional restrictions.

Resale of TI components or services with statements different from or beyond the parameters stated by TI for that component or service voids all express and any implied warranties for the associated TI component or service and is an unfair and deceptive business practice. TI is not responsible or liable for any such statements.

Buyer acknowledges and agrees that it is solely responsible for compliance with all legal, regulatory and safety-related requirements concerning its products, and any use of TI components in its applications, notwithstanding any applications-related information or support that may be provided by TI. Buyer represents and agrees that it has all the necessary expertise to create and implement safeguards which anticipate dangerous consequences of failures, monitor failures and their consequences, lessen the likelihood of failures that might cause harm and take appropriate remedial actions. Buyer will fully indemnify TI and its representatives against any damages arising out of the use of any TI components in safety-critical applications.

In some cases, TI components may be promoted specifically to facilitate safety-related applications. With such components, TI's goal is to help enable customers to design and create their own end-product solutions that meet applicable functional safety standards and requirements. Nonetheless, such components are subject to these terms.

No TI components are authorized for use in FDA Class III (or similar life-critical medical equipment) unless authorized officers of the parties have executed a special agreement specifically governing such use.

Only those TI components which TI has specifically designated as military grade or "enhanced plastic" are designed and intended for use in military/aerospace applications or environments. Buyer acknowledges and agrees that any military or aerospace use of TI components which have **not** been so designated is solely at the Buyer's risk, and that Buyer is solely responsible for compliance with all legal and regulatory requirements in connection with such use.

TI has specifically designated certain components which meet ISO/TS16949 requirements, mainly for automotive use. Components which have not been so designated are neither designed nor intended for automotive use; and TI will not be responsible for any failure of such components to meet such requirements.

Products

Audio	www.ti.com/audio
Amplifiers	amplifier.ti.com
Data Converters	dataconverter.ti.com
DLP® Products	www.dlp.com
DSP	dsp.ti.com
Clocks and Timers	www.ti.com/clocks
Interface	interface.ti.com
Logic	logic.ti.com
Power Mgmt	power.ti.com
Microcontrollers	microcontroller.ti.com
RFID	www.ti-rfid.com
OMAP Applications Processors	www.ti.com/omap
Wireless Connectivity	www.ti.com/wirelessconnectivity

Applications

Automotive and Transportation	www.ti.com/automotive
Communications and Telecom	www.ti.com/communications
Computers and Peripherals	www.ti.com/computers
Consumer Electronics	www.ti.com/consumer-apps
Energy and Lighting	www.ti.com/energy
Industrial	www.ti.com/industrial
Medical	www.ti.com/medical
Security	www.ti.com/security
Space, Avionics and Defense	www.ti.com/space-avionics-defense
Video and Imaging	www.ti.com/video

TI E2E Community

e2e.ti.com