

Low THD, High Performance LED Driver

FEATURES

- Extremely Low input current THD
- Ultra-low ($\leq 50\mu\text{A}$) start - up current
- Zero-current switching and minimum off time control
- Leading edge blanking instead of RC filtering
- Adjustable line compensation
- Adjustable Output Overvoltage Protection (OVP)
- VCC Over Voltage Protection
- Output Short Circuit Protection(OSCP)
- IC Over Temperature Protection(OTP)
- Open control loop protection
- Disable function
- Few external components required
- Dip-8/SOP-8 packages

APPLICATIONS

- AC/DC LED Driver Applications
- Commercial & industrial lighting
- Architecture detail lighting
- Street lamp lighting

DESCRIPTION

The FT822 is a current-mode control PFC LED driver IC. It provides a controlled on-time to regulate the output and achieve natural power factor correction. The highly linear multiplier makes the device capable of working in wide input voltage range applications (from 85V to 265V) with an excellent THD.

The device features extremely low consumption ($\leq 50\mu\text{A}$ before start-up and $\leq 4\text{mA}$ operating) and includes a disable function suitable for IC remote ON/OFF control, which makes it easier to comply with energy saving norms.

The FT822 features fruitful protections like OTP, OVP, OSCP. Adjustable output overvoltage protection(OVP) enables to safely handle overvoltage resulting from load disconnection. Output Short Circuit Protection (OSCP) reduces the input power consumption when Output Short Circuit is detected.

The totem-pole output stage is capable of driving a MOSFET or IGBT with source and sink currents of $\pm 400\text{mA}$ typically. The device is optimized for low THD LED lighting application up to 60W.

TYPICAL APPLICATION CIRCUIT

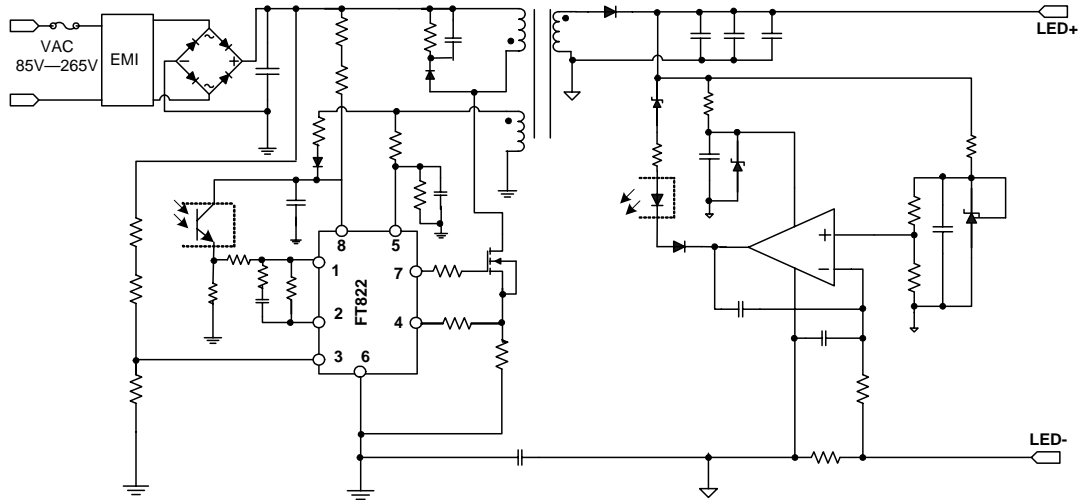

Figure 1: Typical Application Circuit

ABSOLUTE MAXIMUM RATINGS

| | |
|----------------------------------|---------------------------|
| VCC to GND..... | -0.3V to +28V |
| FB to GND | -0.3V to +7V |
| COMP to GND..... | -0.3V to +7V |
| MULT to GND..... | -0.3V to +7V |
| CS to GND..... | -0.3V to 7V |
| IAUX..... | -5mA (source) / 5mA(sink) |
| Operating Temperature Range..... | -40°C to +125°C |
| Junction Temperature..... | -40°C to +150°C |
| Storage Temperature Range | -60°C to +150°C |
| ESD Protection HBM..... | 3500V |
| ESD Protection MM..... | 200V |

* Stresses exceed those listed under “Absolute Maximum Ratings” may cause permanent damage to the device. Functional operation of the device at conditions beyond those listed in the specification is not guaranteed. Prolonged exposure to extreme conditions may affect device reliability or functionality.

PIN CONFIGURATION

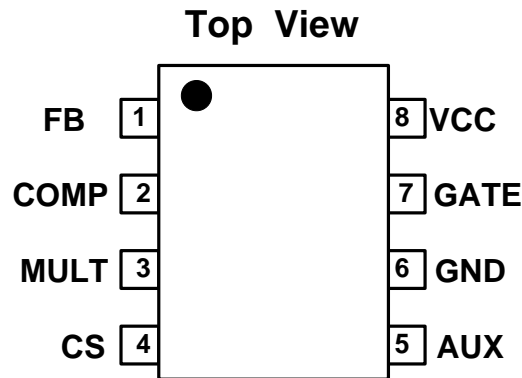

Figure 2: Pin Assignments

TERMINAL DESCRIPTION

| No. | PIN | FUNCTION |
|-----|-------------|---|
| 1 | FB | Inverting input of error amplifier. The information on the output is fed into the pin through an opto-coupler. The pin also as an ON/OFF control input. |
| 2 | COMP | Output of the error amplifier. A compensation network is placed between this pin and FB (pin #1) to achieve stability of the control loop and ensure high power factor and low current THD. |
| 3 | MULT | Main input to the multiplier. This pin is connected to the rectified mains voltage via a resistor divider and provides the sinusoidal reference to the current loop. |
| 4 | CS | Input to the PWM comparator. The current flowing through the MOSFET is sensed by a resistor, the resulting voltage together with line compensation voltage is applied to this pin and compared with an internal sinusoidal-shaped reference, generated by the multiplier, to determine MOSFET's turn-off. |
| 5 | AUX | Input from auxiliary winding sensing resistor divider for demagnetization timing, A negative-going edge after MOSFET's minimum off time triggers MOSFET's turn-on. AUX double as OSCP and adjustable OVP latch protection input. |
| 6 | GND | Ground. |
| 7 | GATE | Gate drive output. |
| 8 | VCC | Supply Voltage of both the signal part of the IC and the gate driver. |

Table1

ORDERING INFORMATION

FT822①

| DESIGNATOR | SYMBOL | PACKAGE TYPE |
|------------|--------|--------------|
| ① | a | SOP-8 |
| | b | DIP-8 |

Table 2

MARKING RULE

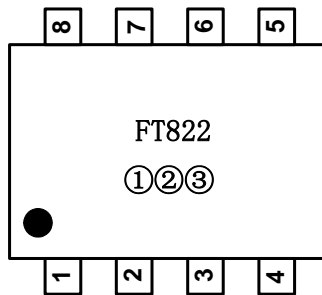
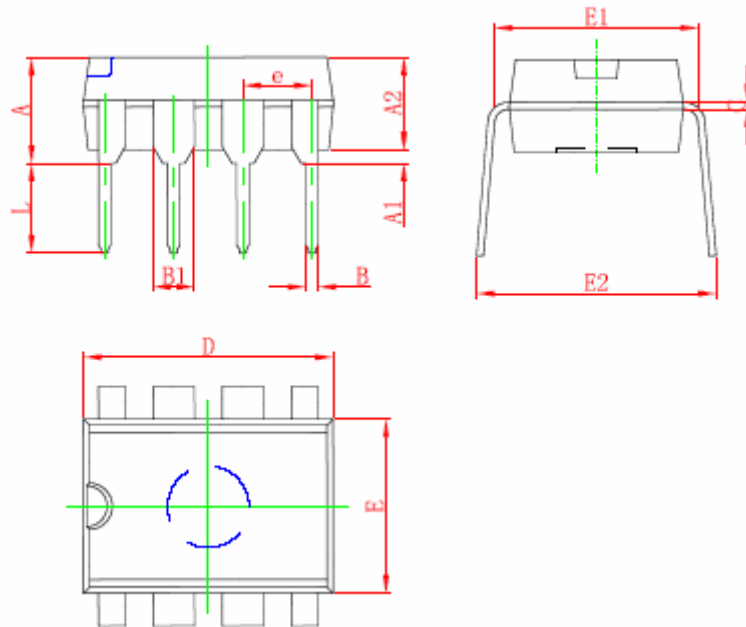

Figure 3 marking rule

①②③ for internal reference

PAKAGING INFORMATION

DIP – 8 Package



| Symbol | Dimensions in Millimeters | | Dimensions in Inches | |
|--------|---------------------------|-------|----------------------|-------|
| | Min | Max | Min | Max |
| A | 3.710 | 4.310 | 0.146 | 0.170 |
| A1 | 0.510 | | 0.020 | |
| A2 | 3.200 | 3.600 | 0.126 | 0.142 |
| B | 0.380 | 0.570 | 0.015 | 0.022 |
| B1 | 1.524 (BSC) | | 0.060 (BSC) | |
| C | 0.204 | 0.360 | 0.008 | 0.014 |
| D | 9.000 | 9.400 | 0.354 | 0.370 |
| E | 6.200 | 6.600 | 0.244 | 0.260 |
| E1 | 7.320 | 7.920 | 0.288 | 0.312 |
| e | 2.540 (BSC) | | 0.100 (BSC) | |
| L | 3.000 | 3.600 | 0.118 | 0.142 |
| E2 | 8.400 | 9.000 | 0.331 | 0.354 |

SOP – 8 Package

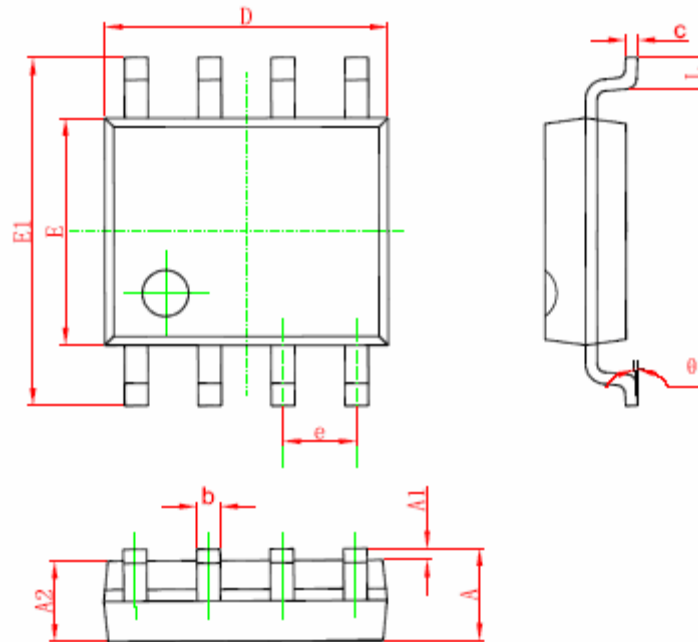

| Symbol | Dimensions in Millimeters | | Dimensions in Inches | |
|--------|---------------------------|-------|----------------------|-------|
| | Min | Max | Min | Max |
| A | 1.350 | 1.750 | 0.053 | 0.069 |
| A1 | 0.100 | 0.250 | 0.004 | 0.010 |
| A2 | 1.350 | 1.550 | 0.053 | 0.061 |
| b | 0.330 | 0.510 | 0.013 | 0.020 |
| c | 0.170 | 0.250 | 0.006 | 0.010 |
| D | 4.700 | 5.100 | 0.185 | 0.200 |
| E | 3.800 | 4.000 | 0.150 | 0.157 |
| E1 | 5.800 | 6.200 | 0.228 | 0.244 |
| e | 1.270 (BSC) | | 0.050 (BSC) | |
| L | 0.400 | 1.270 | 0.016 | 0.050 |
| theta | 0° | 8° | 0° | 8° |