

QUAD SERIAL INTERFACE LOW-SIDE DRIVER IC

 Check for Samples: [DRV8806](#)

FEATURES

- **4-Channel Protected Low-Side Driver**
 - Four NMOS FETs With Overcurrent Protection
 - Integrated Inductive Catch Diodes
 - Serial Interface
 - Open/Shorted Load Detection
- **2-A (Single Channel On)/1-A (All Channels On) Maximum Drive Current per Channel (at 25°C)**
- **8.2-V to 40-V Operating Supply Voltage Range**
- **Thermally Enhanced Surface Mount Package**

APPLICATIONS

- Relay Drivers
- Unipolar Stepper Motor Drivers
- Solenoid Drivers
- General Low-Side Switch Applications

DESCRIPTION

The DRV8806 provides a 4-channel low side driver with overcurrent protection. It has built-in diodes to clamp turn-off transients generated by inductive loads and can be used to drive unipolar stepper motors, DC motors, relays, solenoids, or other loads.

The DRV8806 can supply up to 2-A (single channel on) or 1-A (all channels on) continuous output current (with adequate PCB heatsinking at 25°C).

A serial interface is provided to control the output drivers. Fault status can be read through the serial interface. Multiple DRV8806 devices can be chained together to use a single serial interface.

Internal shutdown functions are provided for over current protection, short circuit protection, under voltage lockout and overtemperature and faults are indicated by a fault output pin.

The DRV8806 is available in a 16-pin HTSSOP package (Eco-friendly: RoHS & no Sb/Br).

ORDERING INFORMATION⁽¹⁾

PACKAGE ⁽²⁾		ORDERABLE PART NUMBER	TOP-SIDE MARKING
(HTSSOP) - PWP	Reel of 2000	DRV8806PWPR	DRV8806
	Tube of 90	DRV8806PWP	DRV8806

(1) For the most current packaging and ordering information, see the Package Option Addendum at the end of this document, or see the TI web site at www.ti.com.

(2) Package drawings, thermal data, and symbolization are available at www.ti.com/packaging.



Please be aware that an important notice concerning availability, standard warranty, and use in critical applications of Texas Instruments semiconductor products and disclaimers thereto appears at the end of this data sheet.

PowerPAD is a trademark of Texas Instruments.

PRODUCTION DATA information is current as of publication date. Products conform to specifications per the terms of the Texas Instruments standard warranty. Production processing does not necessarily include testing of all parameters.

Copyright © 2012, Texas Instruments Incorporated

DEVICE INFORMATION

Functional Block Diagram

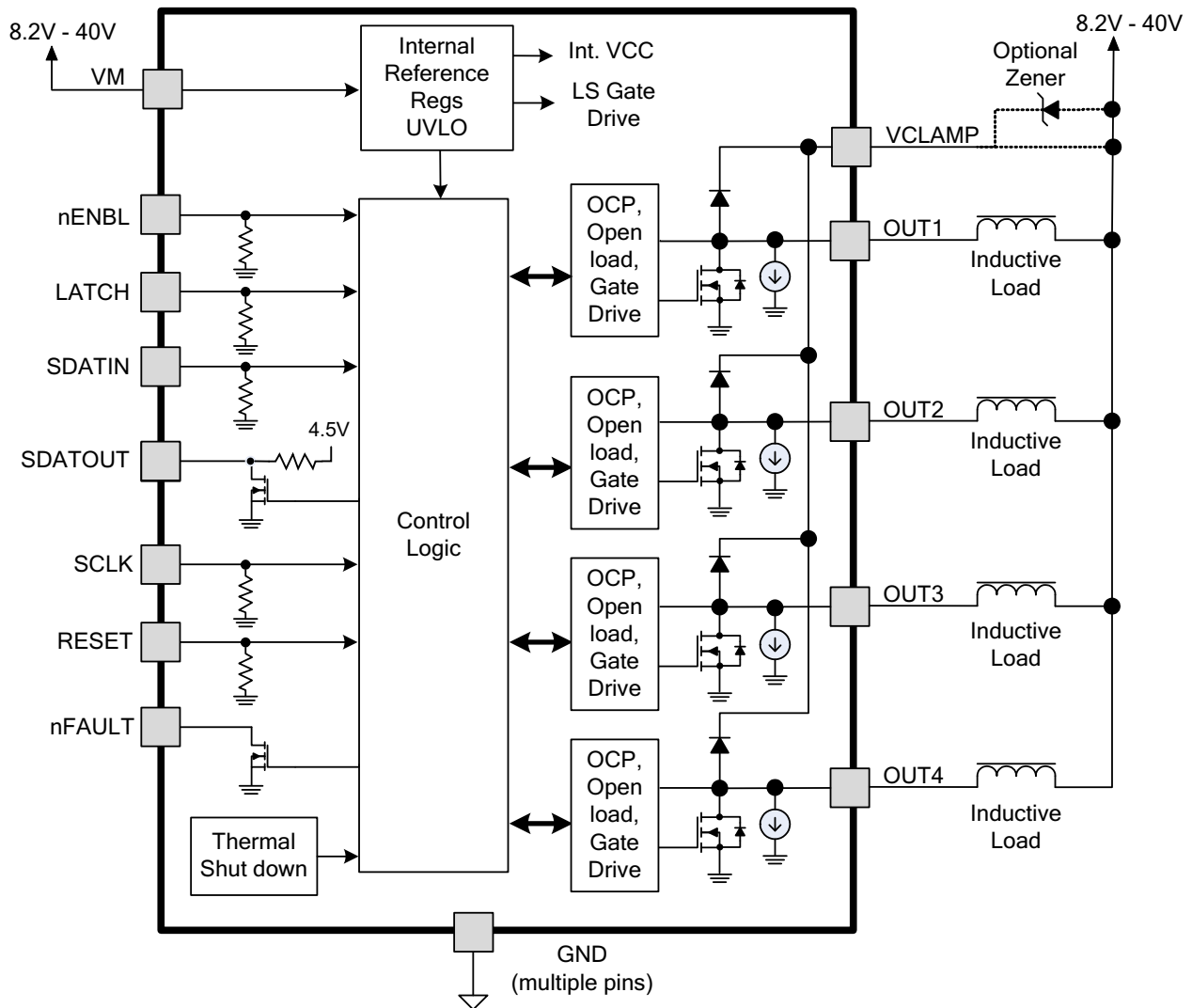
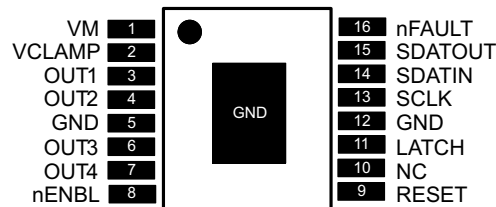

Table 1. TERMINAL FUNCTIONS

NAME	PIN (HTSSOP)	I/O ⁽¹⁾	DESCRIPTION	EXTERNAL COMPONENTS OR CONNECTIONS
POWER AND GROUND				
GND	5, 12, PPAD	-	Device ground	All pins must be connected to GND.
VM	1	-	Device power supply	Connect to motor supply (8.2 V - 40 V).
CONTROL				
nENBL	8	I	Enable input	Active low enables outputs – internal pulldown
RESET	9	I	Reset input	Active-high reset input initializes internal logic – internal pulldown
LATCH	11	I	Latch input	Rising edge latches shift register to output stage, falling edge latches fault data into output shift register – internal pulldown
SDATIN	14	I	Serial data input	Serial data input – internal pulldown
SDATOUT	15	OD	Serial data output	Serial data output - open drain output - internal pullup
SCLK	13	I	Serial clock	Serial clock input – internal pulldown
STATUS				
nFAULT	16	OD	Fault	Logic low when in fault condition (overtemp, overcurrent, open load) - open drain output
OUTPUT				
OUT1	3	O	Output 1	Connect to load 1
OUT2	4	O	Output 2	Connect to load 2
OUT3	6	O	Output 3	Connect to load 3
OUT4	7	O	Output 4	Connect to load 4
VCLAMP	2	-	Output clamp voltage	Connect to VM supply, or zener diode to VM supply

(1) Directions: I = input, O = output, OD = open-drain output

**PWP (HTSSOP) PACKAGE
(TOP VIEW)**

ABSOLUTE MAXIMUM RATINGS

over operating free-air temperature range (unless otherwise noted) ⁽¹⁾ ⁽²⁾

		VALUE	UNIT
VM	Power supply voltage range	–0.3 to 43	V
VOUTx	Output voltage range	–0.3 to 43	V
VCLAMP	Clamp voltage range	–0.3 to 43	V
SDATOUT, nFAULT	Output current	20	mA
	Peak clamp diode current ⁽³⁾	2	A
	DC or RMS clamp diode current ⁽³⁾	1	A
	Digital input pin voltage range	–0.5 to 7	V
SDATOUT, nFAULT	Digital output pin voltage range	–0.5 to 7	V
	Peak motor drive output current, $t < 1 \mu\text{s}$	Internally limited	A
	Continuous total power dissipation ⁽³⁾	See Thermal Information table	
T _J	Operating virtual junction temperature range ⁽³⁾	–40 to 150	°C
T _{stg}	Storage temperature range	–60 to 150	°C

- (1) Stresses beyond those listed under absolute maximum ratings may cause permanent damage to the device. These are stress ratings only, and functional operation of the device at these or any other conditions beyond those indicated under recommended operating conditions is not implied. Exposure to absolute–maximum–rated conditions for extended periods may affect device reliability.
- (2) All voltage values are with respect to network ground terminal.
- (3) Power dissipation and thermal limits must be observed.

THERMAL INFORMATION

THERMAL METRIC ⁽¹⁾		DRV8806	UNITS
		PWP	
		16 PINS	
θ_{JA}	Junction-to-ambient thermal resistance ⁽²⁾	39.6	°C/W
$\theta_{Jc\text{top}}$	Junction-to-case (top) thermal resistance ⁽³⁾	24.6	
θ_{JB}	Junction-to-board thermal resistance ⁽⁴⁾	20.3	
ψ_{JT}	Junction-to-top characterization parameter ⁽⁵⁾	0.7	
ψ_{JB}	Junction-to-board characterization parameter ⁽⁶⁾	20.1	
$\theta_{Jc\text{bot}}$	Junction-to-case (bottom) thermal resistance ⁽⁷⁾	2.3	

- (1) For more information about traditional and new thermal metrics, see the *IC Package Thermal Metrics* application report, [SPRA953](#).
- (2) The junction-to-ambient thermal resistance under natural convection is obtained in a simulation on a JEDEC-standard, high-K board, as specified in JESD51-7, in an environment described in JESD51-2a.
- (3) The junction-to-case (top) thermal resistance is obtained by simulating a cold plate test on the package top. No specific JEDEC-standard test exists, but a close description can be found in the ANSI SEMI standard G30-88.
- (4) The junction-to-board thermal resistance is obtained by simulating in an environment with a ring cold plate fixture to control the PCB temperature, as described in JESD51-8.
- (5) The junction-to-top characterization parameter, ψ_{JT} , estimates the junction temperature of a device in a real system and is extracted from the simulation data for obtaining θ_{JA} , using a procedure described in JESD51-2a (sections 6 and 7).
- (6) The junction-to-board characterization parameter, ψ_{JB} , estimates the junction temperature of a device in a real system and is extracted from the simulation data for obtaining θ_{JA} , using a procedure described in JESD51-2a (sections 6 and 7).
- (7) The junction-to-case (bottom) thermal resistance is obtained by simulating a cold plate test on the exposed (power) pad. No specific JEDEC standard test exists, but a close description can be found in the ANSI SEMI standard G30-88.

RECOMMENDED OPERATING CONDITIONS

		MIN	NOM	MAX	UNIT
V_M	Power supply voltage range	8.2		40	V
V_{CLAMP}	Output clamp voltage range ⁽¹⁾	0		40	V
I_{OUT}	Continuous output current, single channel on, $T_A = 25^\circ\text{C}$ ⁽²⁾			2	A
	Continuous output current, four channels on, $T_A = 25^\circ\text{C}$ ⁽²⁾			1	

(1) V_{CLAMP} is not a power supply input pin - it only connects to the output clamp diodes.

(2) Power dissipation and thermal limits must be observed.

ELECTRICAL CHARACTERISTICS

$T_A = 25^\circ\text{C}$, over recommended operating conditions (unless otherwise noted)

PARAMETER		TEST CONDITIONS	MIN	TYP	MAX	UNIT
POWER SUPPLIES						
I_{VM}	VM operating supply current	$V_M = 24\text{ V}$		1.6	3	mA
V_{UVLO}	VM undervoltage lockout voltage	V_M rising			8.2	V
LOGIC-LEVEL INPUTS (SCHMITT TRIGGER INPUTS WITH HYSTERESIS)						
V_{IL}	Input low voltage				0.8	V
V_{IH}	Input high voltage		2			V
V_{HYS}	Input hysteresis			0.45		V
I_{IL}	Input low current	$V_{IN} = 0$	-20		20	μA
I_{IH}	Input high current	$V_{IN} = 3.3\text{ V}$			100	μA
R_{PD}	Pulldown resistance			100		k Ω
nFAULT OUTPUT (OPEN-DRAIN OUTPUT)						
V_{OL}	Output low voltage	$I_O = 5\text{ mA}$			0.5	V
I_{OH}	Output high leakage current	$V_O = 3.3\text{ V}$			1	μA
SDATOUT OUTPUT (OPEN-DRAIN OUTPUT WITH INTERNAL PULLUP)						
V_{OL}	Output low voltage	$I_O = 5\text{ mA}$		0.5		V
V_{OH}	Output high voltage	$I_O = 100\text{ }\mu\text{A}$		4.5		V
LOW-SIDE FETS						
$R_{DS(ON)}$	FET on resistance	$V_M = 24\text{ V}$, $I_O = 700\text{ mA}$, $T_J = 25^\circ\text{C}$		0.5		Ω
		$V_M = 24\text{ V}$, $I_O = 700\text{ mA}$, $T_J = 85^\circ\text{C}$		0.75	0.8	
I_{OFF}	Open load detect current		0	25	50	μA
HIGH-SIDE DIODES						
V_F	Diode forward voltage	$V_M = 24\text{ V}$, $I_O = 700\text{ mA}$, $T_J = 25^\circ\text{C}$		0.9		V
I_{OFF}	Off state leakage current	$V_M = 24\text{ V}$, $T_J = 25^\circ\text{C}$	-50		50	μA
OUTPUTS						
t_R	Rise time	$V_M = 24\text{ V}$, $I_O = 700\text{ mA}$, Resistive load	50		300	ns
t_F	Fall time	$V_M = 24\text{ V}$, $I_O = 700\text{ mA}$, Resistive load	50		150	ns
PROTECTION CIRCUITS						
I_{OCP}	Overcurrent protection trip level		3		5	A
t_{OCP}	Overcurrent protection deglitch time			3.5		μs
t_{OL}	Open load detect deglitch time			15		μs
t_{RETRY}	Overcurrent protection re-try time			1.2		ms
t_{TSD}	Thermal shutdown temperature	Die temperature	150	160	180	$^\circ\text{C}$

TIMING REQUIREMENTS

over operating free-air temperature range (unless otherwise noted)⁽¹⁾

NO.	PARAMETER	DESCRIPTION	MIN	MAX	UNIT
1	t_{CYC}	Clock cycle time	62		ns
2	t_{CLKH}	Clock high time	25		ns
3	t_{CLKL}	Clock low time	25		ns
4	$t_{SU(SDATIN)}$	Setup time, SDATIN to SCLK	5		ns
5	$t_{H(SDATIN)}$	Hold time, SDATIN to SCLK	1		ns
6	$t_{D(SDATOUT)}$	Delay time, SCLK to SDATOUT		15	ns
7	$t_{W(LATCH)}$	Pulse width, LATCH	200		ns
8	$t_{OE(ENABLE)}$	Enable time, nENBL to output low		50	ns
9	$t_{D(LATCH)}$	Delay time, LATCH to output change		50	ns
-	t_{RESET}	RESET pulse width	20		μ s
10	$t_{D(RESET)}$	Reset delay before clock	20		μ s
11	$t_{STARTUP}$	Startup delay VM applied before clock	55		μ s

(1) Not production tested.

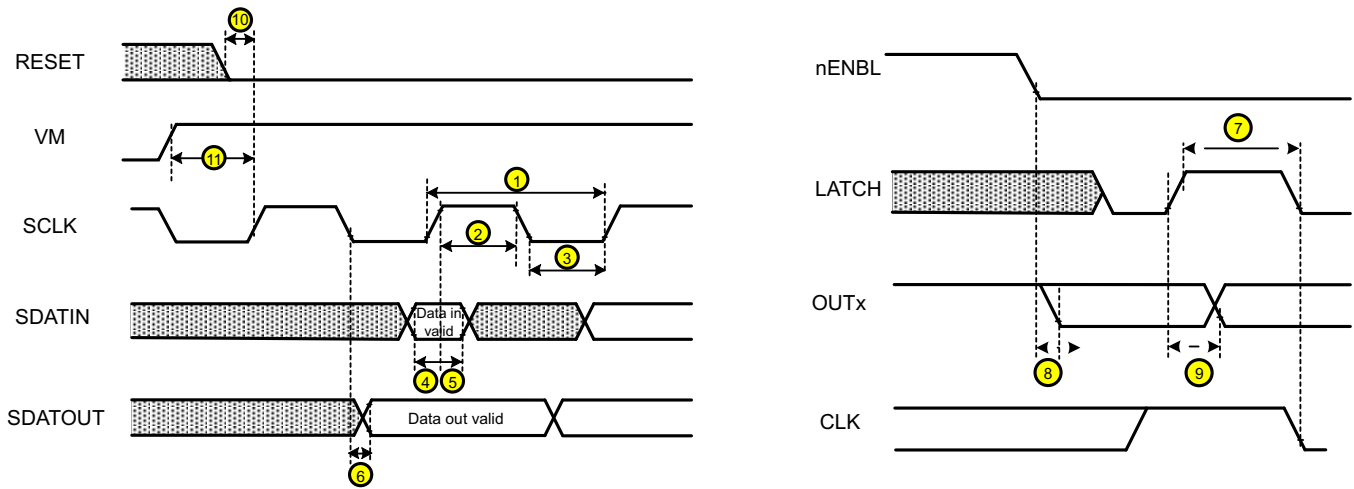

Figure 1. DRV8806 Timing Requirements

Fault Output Register

The DRV8806 contains circuitry to detect open or shorted loads. The status of the loads can be read via the serial interface. The logic is shown in Figure 3.

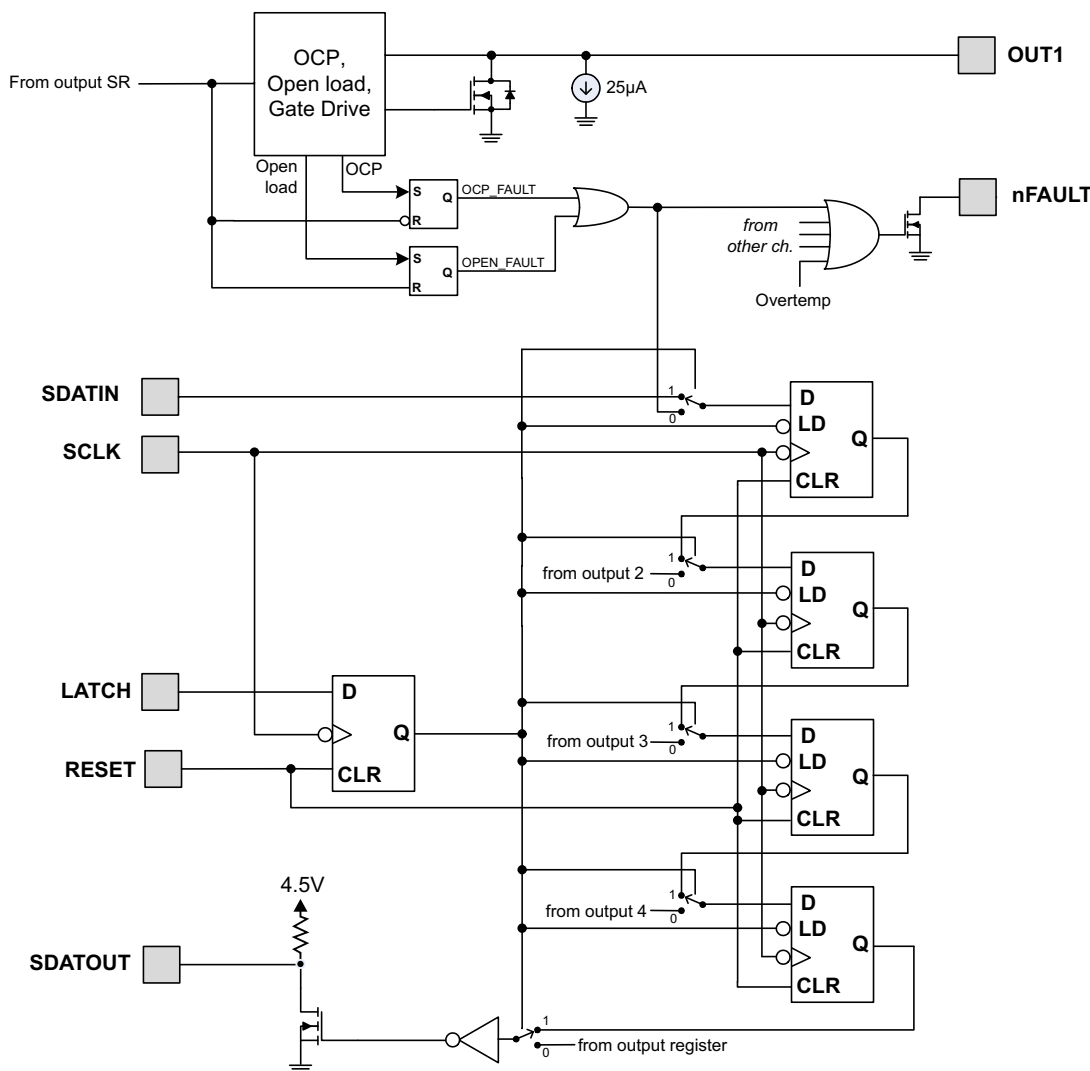

Figure 3. Fault Output

To overcome any leakage currents to accurately sense an open load, a small current source is connected to each output pin. This source pulls approximately 25-µA of current to ground. The voltage on the output pin is sensed during the time that the output is off, and if the voltage on the pin is less than 1.2 V (indicating that there is no load connected) after the open load deglitch time, the OPEN_FAULT latch is set. This latch is cleared whenever the output bit is set.

When the output is turned on, if an overcurrent (OCP) fault is detected, the channel will be turned off and the OCP_FAULT latch is set. This latch will be cleared whenever the output bit is cleared.

The state of the OCP_FAULT and OPEN_FAULT signals is combined into a single fault bit per channel, and loaded into a shift register while the LATCH pin is low. When the LATCH pin is taken high, the fault data is latched into the shift register at the first falling edge of SCLK. Data may then be shifted out on the SDATOUT pin on each falling edge of the SCLK pin.

Note that the LATCH signal must be high for a minimum of 200 ns before valid data can be clocked out.

The nFAULT pin will be driven active low whenever any of the OCP_FAULT or OPEN_FAULT latches are set, as well as whenever there is an overtemperature condition.

Daisy-Chain Connection

Two or more DRV8806 devices may be connected together to use a single serial interface. The SDATOUT pin of the first device in the chain is connected to the SDATIN pin of the next device. The SCLK, LATCH, RESET, and nFAULT pins are connected together.

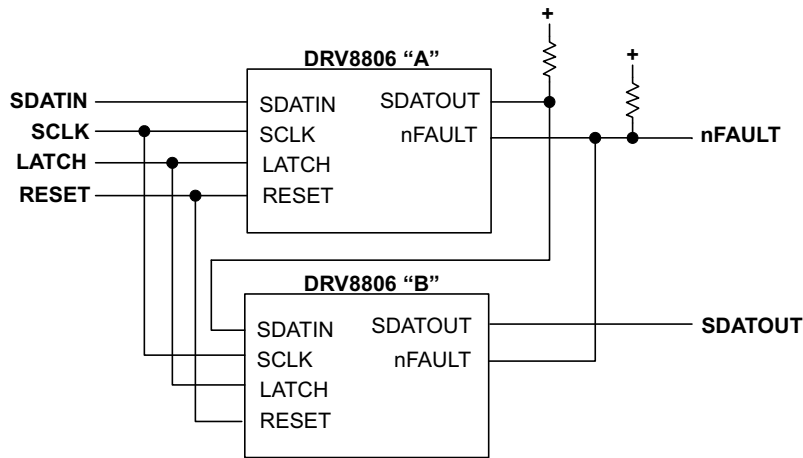

Figure 4. Daisy-Chain Connection

Figure 5 shows an example of a serial transaction, writing the output bits, and then reading the fault status bits, using two devices connected together in a daisy-chain.

Note that the LATCH signal must be high for a minimum of 200 ns before valid data can be clocked out.

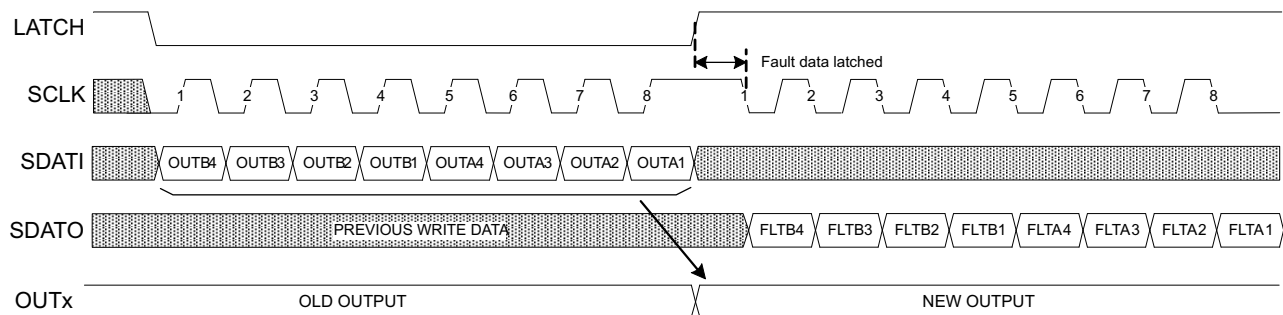

Figure 5. Daisy-Chain Serial Transaction

nENBL and RESET Operation

The nENBL pin enables or disables the output drivers. nENBL must be low to enable the outputs. nENBL does not affect the operation of the serial interface logic. Note that nENBL has an internal pulldown.

The RESET pin, when driven active high, resets internal logic, including the OCP fault. All serial interface registers are cleared. Note that RESET has an internal pulldown. An internal power-up reset is also provided, so it is not required to drive RESET at power-up.

Protection Circuits

The DRV8806 is fully protected against undervoltage, overcurrent and overtemperature events.

Overcurrent Protection (OCP)

An analog current limit circuit on each FET limits the current through the FET by removing the gate drive. If this analog current limit persists for longer than the t_{OCP} deglitch time (approximately 3.5 μs), the driver will be disabled and the nFAULT pin will be driven low. The driver will remain disabled for the t_{RETRY} retry time (approximately 1.2 ms), then the fault will be automatically cleared. The fault will be cleared immediately if either RESET pin is activated or VM is removed and re-applied.

Thermal Shutdown (TSD)

If the die temperature exceeds safe limits, all output FETs will be disabled and the nFAULT pin will be driven low. Once the die temperature has fallen to a safe level, operation will automatically resume.

Undervoltage Lockout (UVLO)

If at any time the voltage on the VM pin falls below the undervoltage lockout threshold voltage, all circuitry in the device will be disabled, and internal logic will be reset. Operation will resume when VM rises above the UVLO threshold.

THERMAL INFORMATION

Thermal Protection

The DRV8806 has thermal shutdown (TSD) as described above. If the die temperature exceeds approximately 150°C, the device will be disabled until the temperature drops to a safe level.

Any tendency of the device to enter TSD is an indication of either excessive power dissipation, insufficient heatsinking, or too high an ambient temperature.

Power Dissipation

Power dissipation in the DRV8806 is dominated by the power dissipated in the output FET resistance, or $R_{DS(ON)}$. Average power dissipation of each FET when running a static load can be roughly estimated by [Equation 1](#):

$$P = R_{DS(ON)} \cdot (I_{OUT})^2 \quad (1)$$

where P is the power dissipation of one FET, $R_{DS(ON)}$ is the resistance of each FET, and I_{OUT} is equal to the average current drawn by the load. Note that at start-up and fault conditions this current is much higher than normal running current; these peak currents and their duration also need to be taken into consideration. When driving more than one load simultaneously, the power in all active output stages must be summed.

The maximum amount of power that can be dissipated in the device is dependent on ambient temperature and heatsinking.

Note that $R_{DS(ON)}$ increases with temperature, so as the device heats, the power dissipation increases. This must be taken into consideration when sizing the heatsink.

Heatsinking

The PowerPAD™ package uses an exposed pad to remove heat from the device. For proper operation, this pad must be thermally connected to copper on the PCB to dissipate heat. On a multi-layer PCB with a ground plane, this can be accomplished by adding a number of vias to connect the thermal pad to the ground plane. On PCBs without internal planes, copper area can be added on either side of the PCB to dissipate heat. If the copper area is on the opposite side of the PCB from the device, thermal vias are used to transfer the heat between top and bottom layers.

For details about how to design the PCB, refer to TI Application Report [SLMA002](#), "PowerPAD™ Thermally Enhanced Package" and TI Application Brief [SLMA004](#), "PowerPAD™ Made Easy", available at www.ti.com.

In general, the more copper area that can be provided, the more power can be dissipated.

PACKAGING INFORMATION

Orderable Device	Status ⁽¹⁾	Package Type	Package Drawing	Pins	Package Qty	Eco Plan ⁽²⁾	Lead/ Ball Finish	MSL Peak Temp ⁽³⁾	Samples (Requires Login)
DRV8806PWP	ACTIVE	HTSSOP	PWP	16	90	Green (RoHS & no Sb/Br)	CU NIPDAU	Level-3-260C-168 HR	
DRV8806PWPR	ACTIVE	HTSSOP	PWP	16	2000	Green (RoHS & no Sb/Br)	CU NIPDAU	Level-3-260C-168 HR	

⁽¹⁾ The marketing status values are defined as follows:

ACTIVE: Product device recommended for new designs.

LIFEBUY: TI has announced that the device will be discontinued, and a lifetime-buy period is in effect.

NRND: Not recommended for new designs. Device is in production to support existing customers, but TI does not recommend using this part in a new design.

PREVIEW: Device has been announced but is not in production. Samples may or may not be available.

OBsolete: TI has discontinued the production of the device.

⁽²⁾ Eco Plan - The planned eco-friendly classification: Pb-Free (RoHS), Pb-Free (RoHS Exempt), or Green (RoHS & no Sb/Br) - please check <http://www.ti.com/productcontent> for the latest availability information and additional product content details.

TBD: The Pb-Free/Green conversion plan has not been defined.

Pb-Free (RoHS): TI's terms "Lead-Free" or "Pb-Free" mean semiconductor products that are compatible with the current RoHS requirements for all 6 substances, including the requirement that lead not exceed 0.1% by weight in homogeneous materials. Where designed to be soldered at high temperatures, TI Pb-Free products are suitable for use in specified lead-free processes.

Pb-Free (RoHS Exempt): This component has a RoHS exemption for either 1) lead-based flip-chip solder bumps used between the die and package, or 2) lead-based die adhesive used between the die and leadframe. The component is otherwise considered Pb-Free (RoHS compatible) as defined above.

Green (RoHS & no Sb/Br): TI defines "Green" to mean Pb-Free (RoHS compatible), and free of Bromine (Br) and Antimony (Sb) based flame retardants (Br or Sb do not exceed 0.1% by weight in homogeneous material)

⁽³⁾ MSL, Peak Temp. -- The Moisture Sensitivity Level rating according to the JEDEC industry standard classifications, and peak solder temperature.

Important Information and Disclaimer: The information provided on this page represents TI's knowledge and belief as of the date that it is provided. TI bases its knowledge and belief on information provided by third parties, and makes no representation or warranty as to the accuracy of such information. Efforts are underway to better integrate information from third parties. TI has taken and continues to take reasonable steps to provide representative and accurate information but may not have conducted destructive testing or chemical analysis on incoming materials and chemicals. TI and TI suppliers consider certain information to be proprietary, and thus CAS numbers and other limited information may not be available for release.

In no event shall TI's liability arising out of such information exceed the total purchase price of the TI part(s) at issue in this document sold by TI to Customer on an annual basis.

TAPE AND REEL INFORMATION

REEL DIMENSIONS



TAPE DIMENSIONS



A0	Dimension designed to accommodate the component width
B0	Dimension designed to accommodate the component length
K0	Dimension designed to accommodate the component thickness
W	Overall width of the carrier tape
P1	Pitch between successive cavity centers

TAPE AND REEL INFORMATION

*All dimensions are nominal

Device	Package Type	Package Drawing	Pins	SPQ	Reel Diameter (mm)	Reel Width W1 (mm)	A0 (mm)	B0 (mm)	K0 (mm)	P1 (mm)	W (mm)	Pin1 Quadrant
DRV8806PWPR	HTSSOP	PWP	16	2000	330.0	12.4	6.9	5.6	1.6	8.0	12.0	Q1

TAPE AND REEL BOX DIMENSIONS



*All dimensions are nominal

Device	Package Type	Package Drawing	Pins	SPQ	Length (mm)	Width (mm)	Height (mm)
DRV8806PWPR	HTSSOP	PWP	16	2000	367.0	367.0	35.0

PWP (R-PDSO-G16)

PowerPAD™ PLASTIC SMALL OUTLINE

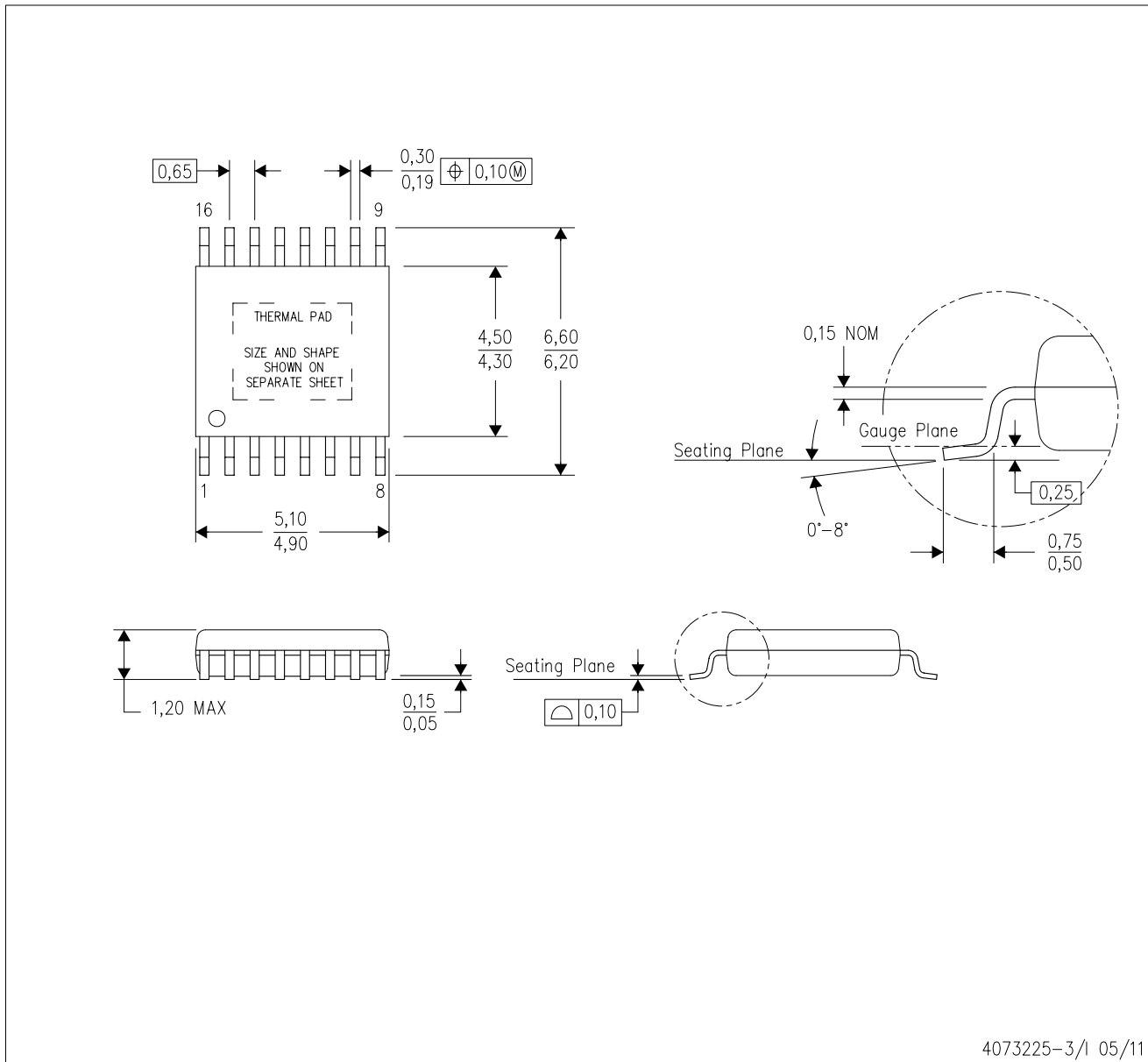

- NOTES:
- A. All linear dimensions are in millimeters.
 - B. This drawing is subject to change without notice.
 - C. Body dimensions do not include mold flash or protrusions. Mold flash and protrusion shall not exceed 0.15 per side.
 - D. This package is designed to be soldered to a thermal pad on the board. Refer to Technical Brief, PowerPad Thermally Enhanced Package, Texas Instruments Literature No. SLMA002 for information regarding recommended board layout. This document is available at www.ti.com <<http://www.ti.com>>.
 - E. See the additional figure in the Product Data Sheet for details regarding the exposed thermal pad features and dimensions.
 - E. Falls within JEDEC MO-153

PowerPAD is a trademark of Texas Instruments.

THERMAL PAD MECHANICAL DATA

PWP (R-PDSO-G16)

PowerPAD™ SMALL PLASTIC OUTLINE

THERMAL INFORMATION

This PowerPAD™ package incorporates an exposed thermal pad that is designed to be attached to a printed circuit board (PCB). The thermal pad must be soldered directly to the PCB. After soldering, the PCB can be used as a heatsink. In addition, through the use of thermal vias, the thermal pad can be attached directly to the appropriate copper plane shown in the electrical schematic for the device, or alternatively, can be attached to a special heatsink structure designed into the PCB. This design optimizes the heat transfer from the integrated circuit (IC).

For additional information on the PowerPAD package and how to take advantage of its heat dissipating abilities, refer to Technical Brief, PowerPAD Thermally Enhanced Package, Texas Instruments Literature No. SLMA002 and Application Brief, PowerPAD Made Easy, Texas Instruments Literature No. SLMA004. Both documents are available at www.ti.com.

The exposed thermal pad dimensions for this package are shown in the following illustration.

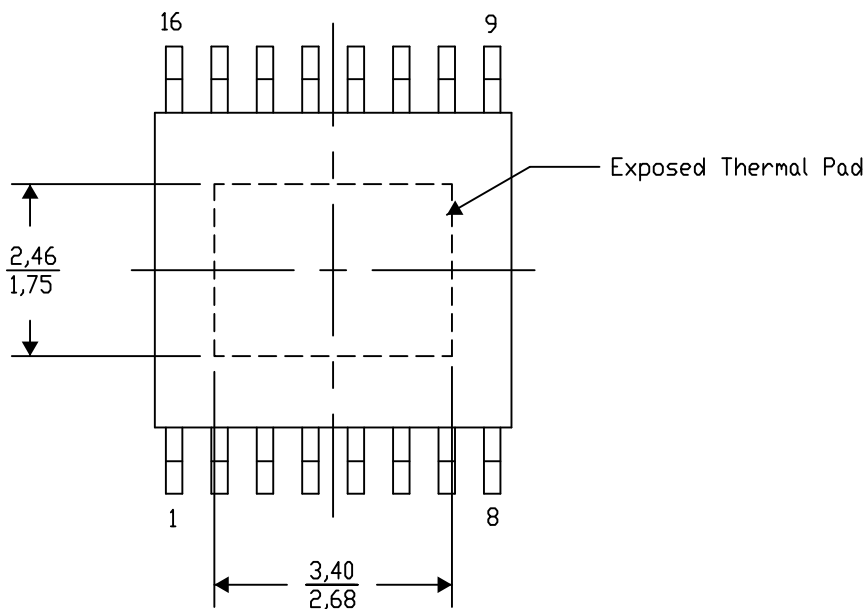

Top View

Exposed Thermal Pad Dimensions

4206332-7/AC 07/12

NOTE: A. All linear dimensions are in millimeters

PowerPAD is a trademark of Texas Instruments

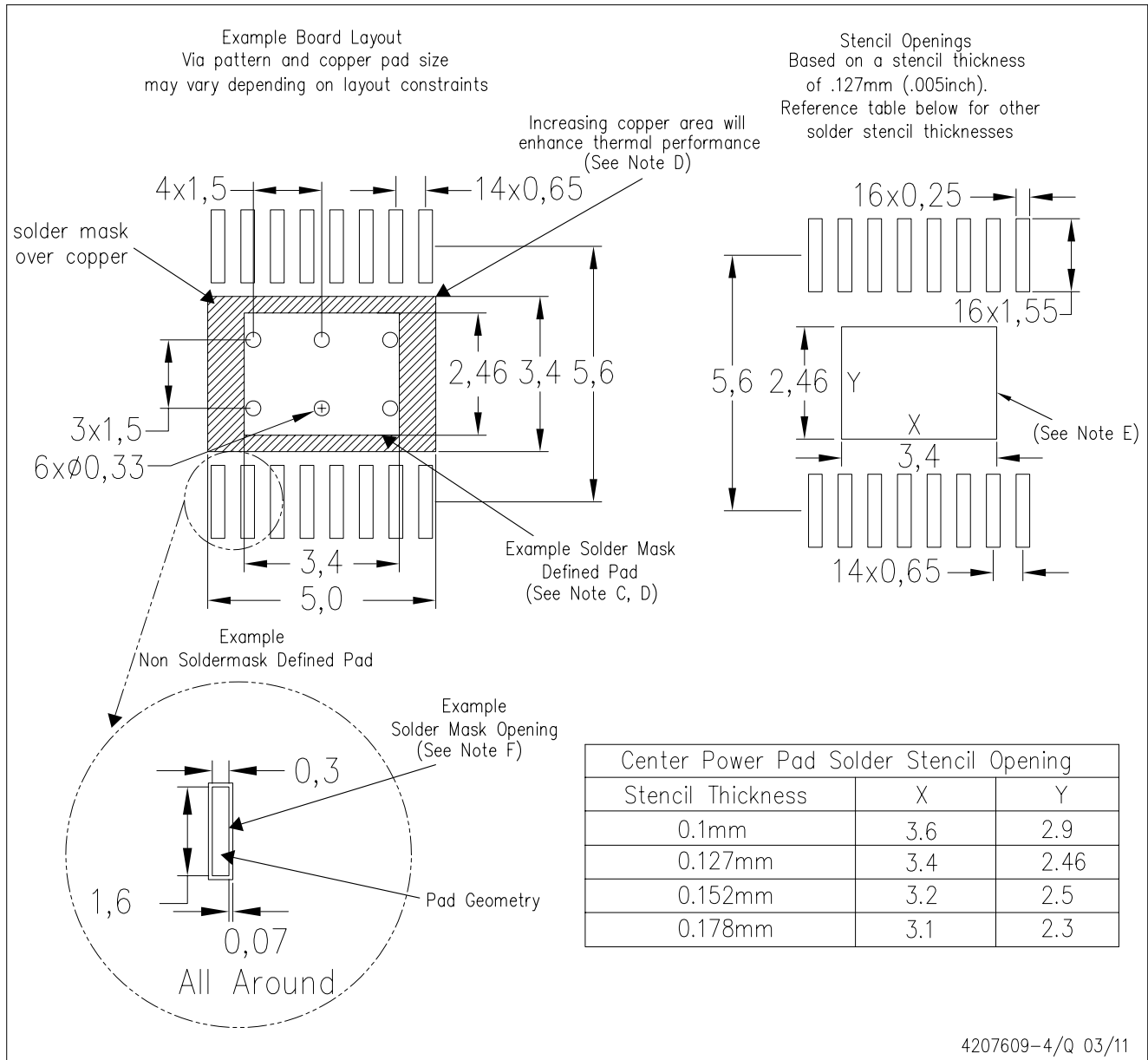

- NOTES:
- A. All linear dimensions are in millimeters.
 - B. This drawing is subject to change without notice.
 - C. Customers should place a note on the circuit board fabrication drawing not to alter the center solder mask defined pad.
 - D. This package is designed to be soldered to a thermal pad on the board. Refer to Technical Brief, PowerPad Thermally Enhanced Package, Texas Instruments Literature No. SLMA002, SLMA004, and also the Product Data Sheets for specific thermal information, via requirements, and recommended board layout. These documents are available at www.ti.com <<http://www.ti.com>>. Publication IPC-7351 is recommended for alternate designs.
 - E. Laser cutting apertures with trapezoidal walls and also rounding corners will offer better paste release. Customers should contact their board assembly site for stencil design recommendations. Example stencil design based on a 50% volumetric metal load solder paste. Refer to IPC-7525 for other stencil recommendations.
 - F. Customers should contact their board fabrication site for solder mask tolerances between and around signal pads.

PowerPAD is a trademark of Texas Instruments.

IMPORTANT NOTICE

Texas Instruments Incorporated and its subsidiaries (TI) reserve the right to make corrections, enhancements, improvements and other changes to its semiconductor products and services per JESD46C and to discontinue any product or service per JESD48B. Buyers should obtain the latest relevant information before placing orders and should verify that such information is current and complete. All semiconductor products (also referred to herein as "components") are sold subject to TI's terms and conditions of sale supplied at the time of order acknowledgment.

TI warrants performance of its components to the specifications applicable at the time of sale, in accordance with the warranty in TI's terms and conditions of sale of semiconductor products. Testing and other quality control techniques are used to the extent TI deems necessary to support this warranty. Except where mandated by applicable law, testing of all parameters of each component is not necessarily performed.

TI assumes no liability for applications assistance or the design of Buyers' products. Buyers are responsible for their products and applications using TI components. To minimize the risks associated with Buyers' products and applications, Buyers should provide adequate design and operating safeguards.

TI does not warrant or represent that any license, either express or implied, is granted under any patent right, copyright, mask work right, or other intellectual property right relating to any combination, machine, or process in which TI components or services are used. Information published by TI regarding third-party products or services does not constitute a license to use such products or services or a warranty or endorsement thereof. Use of such information may require a license from a third party under the patents or other intellectual property of the third party, or a license from TI under the patents or other intellectual property of TI.

Reproduction of significant portions of TI information in TI data books or data sheets is permissible only if reproduction is without alteration and is accompanied by all associated warranties, conditions, limitations, and notices. TI is not responsible or liable for such altered documentation. Information of third parties may be subject to additional restrictions.

Resale of TI components or services with statements different from or beyond the parameters stated by TI for that component or service voids all express and any implied warranties for the associated TI component or service and is an unfair and deceptive business practice. TI is not responsible or liable for any such statements.

Buyer acknowledges and agrees that it is solely responsible for compliance with all legal, regulatory and safety-related requirements concerning its products, and any use of TI components in its applications, notwithstanding any applications-related information or support that may be provided by TI. Buyer represents and agrees that it has all the necessary expertise to create and implement safeguards which anticipate dangerous consequences of failures, monitor failures and their consequences, lessen the likelihood of failures that might cause harm and take appropriate remedial actions. Buyer will fully indemnify TI and its representatives against any damages arising out of the use of any TI components in safety-critical applications.

In some cases, TI components may be promoted specifically to facilitate safety-related applications. With such components, TI's goal is to help enable customers to design and create their own end-product solutions that meet applicable functional safety standards and requirements. Nonetheless, such components are subject to these terms.

No TI components are authorized for use in FDA Class III (or similar life-critical medical equipment) unless authorized officers of the parties have executed a special agreement specifically governing such use.

Only those TI components which TI has specifically designated as military grade or "enhanced plastic" are designed and intended for use in military/aerospace applications or environments. Buyer acknowledges and agrees that any military or aerospace use of TI components which have **not** been so designated is solely at the Buyer's risk, and that Buyer is solely responsible for compliance with all legal and regulatory requirements in connection with such use.

TI has specifically designated certain components which meet ISO/TS16949 requirements, mainly for automotive use. Components which have not been so designated are neither designed nor intended for automotive use; and TI will not be responsible for any failure of such components to meet such requirements.

Products

Audio	www.ti.com/audio
Amplifiers	amplifier.ti.com
Data Converters	dataconverter.ti.com
DLP® Products	www.dlp.com
DSP	dsp.ti.com
Clocks and Timers	www.ti.com/clocks
Interface	interface.ti.com
Logic	logic.ti.com
Power Mgmt	power.ti.com
Microcontrollers	microcontroller.ti.com
RFID	www.ti-rfid.com
OMAP Mobile Processors	www.ti.com/omap
Wireless Connectivity	www.ti.com/wirelessconnectivity

Applications

Automotive and Transportation	www.ti.com/automotive
Communications and Telecom	www.ti.com/communications
Computers and Peripherals	www.ti.com/computers
Consumer Electronics	www.ti.com/consumer-apps
Energy and Lighting	www.ti.com/energy
Industrial	www.ti.com/industrial
Medical	www.ti.com/medical
Security	www.ti.com/security
Space, Avionics and Defense	www.ti.com/space-avionics-defense
Video and Imaging	www.ti.com/video

TI E2E Community e2e.ti.com